

BandSorb® ST

Thin, flexible, Resonant magnetically loaded Microwave Absorber

Description:

BandSorb® ST is a series of resonant absorbers which reflect -20 dB or less of normally incident microwave energy at the design frequency in the range of 1.5 to 40 GHz.

BandSorb® ST can be used for applications requiring absorption at a specific frequency or in a narrow frequency band.

Availability:

BandSorb® ST series materials can be supplied in sheets as well as custom configurations. The standard sheet size is 300 mm x 300 mm.

BandSorb® ST has a varying thickness according to the desired resonant frequency.

Grades are designated by a suffix corresponding to the resonant frequency.

Features and Benefits

BandSorb® ST consists of a thin, flexible, high-loss, magnetically loaded, electrically non-conductive silicone rubber. Silicone absorbers have high service temperature capability (170°C continuous) and allow short exposures to higher temperatures.

Applications

BandSorb® ST series can be used to absorb at a specific frequency or in a narrow frequency band, including:

- Attaching to masts of ships, walls, etc. to reduce reflections and echoes from nearby antennas
- Attaching to vehicles to reduce radar signature.
- Lining magnetron housings to prevent detuning.
- Fabricating into tapered shapes for impedance matching in waveguide or microstrip applications.
- Suppressing reflections, surface currents and cavity resonances inside microwave modules.
- Lining of cavity backed and shrouded telecommunication antennas where narrowband performance is required e.g. waveguide feeds.

For module interference, cavity resonance and surface current problems where no specular reflectivity performance is required, BandSorb® ST, is recommended due to its high magnetic loss properties and will conform to mild curvatures.

Physical Properties:

Datasheet for Performance Characteristics			
CHARACTERISTICS	TEST	UNIT	SPECIFICATIONS
Design Frequency range		GHz	1.5 to 40
Thicknesses		mm (inch)	0.5 - 3.0 (0.019 - 0.118)
Typical Size		mm (inch)	300 x 300 (11.8 x 11.8)
Elastomer Binder			Silicone
Hardness	ASTM D 2240	Shore A	50-95
Elongation	ASTM D 412	%	10-180
Tensile Strength	ASTM D 412	MPa (psi)	2-6 (479)
Maximum service Temperature		°C (°F)	170 (338)
Flammability Rating	UL94*	-	V0
Color	-	-	Grey
Volume Resistivity	ASTM D 991	Ω-cm (Ω-in)	> 10 ¹⁰ (>4 x 10 ⁹)
Compliance			2011/65/EU(RoHS 2.0) Compliance, REACH SVHC Compliance, Halogen free

SEM, Inc.
1555 Jefferson Road,
Rochester, NY 14623
Tel: +1 585-643-2000

SEM BELGIUM bv
Schatting 73
BE-8210 Zedelgem
Belgium
Tel. +32 59 56 02 70

Schlegel Electronic Materials Asia Limited
Unit 1, 3/F, Block A
New Trade Plaza
6 On Ping Street
Shatin, N.T., Hong Kong
Tel: +852 2686 8168

*Tested in accordance of UL94 specification

-The technical specification data is based on SEM tests and analysis that we believe to be reliable. However, in no event, shall SEM be liable for inaccuracies or omissions contained therein. In all cases, details and values should be verified by the customer

Electromagnetic Properties

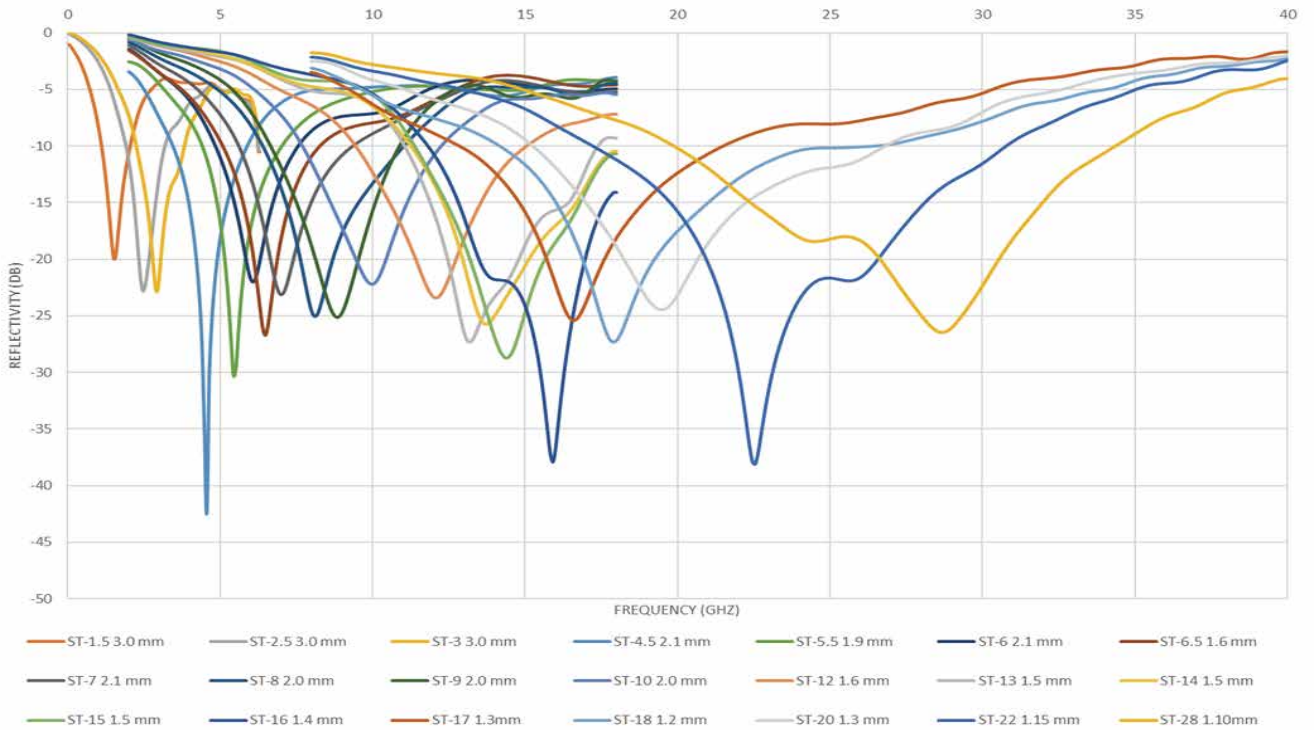

Application example

Example 1 – To remove reflection from substrate.

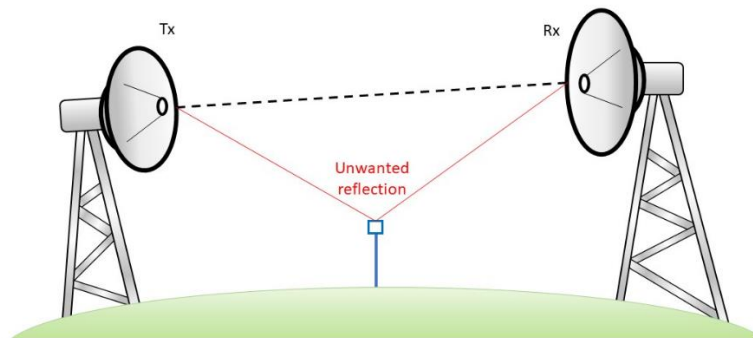

SEM, Inc.
 1555 Jefferson Road,
 Rochester, NY 14623
 Tel: +1 585-643-2000

SEM BELGIUM bv
 Schatting 73
 BE-8210 Zedelgem
 Belgium
 Tel. +32 59 56 02 70

Schlegel Electronic Materials Asia Limited
 Unit 1, 3/F, Block A
 New Trade Plaza
 6 On Ping Street
 Shatin, N.T., Hong Kong
 Tel: +852 2686 8168

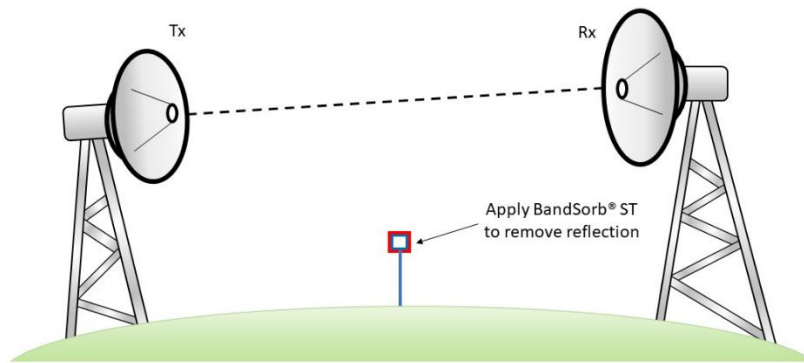

Instructions for use :

BandSorb® ST is designed to function directly in front of a metallic surface. If this is not the case, a metallic foil should first be bonded to the object.

BandSorb® ST materials can be supplied with or without pressure sensitive adhesive (PSA). It can be readily cut with or a sharp knife.

It is a very flexible material and will conform to mild curvatures.

Part number system example

ST - 15 - A
 Product name Resonant Frequency (GHz) with Pressure Sensitive Adhesive: A, blank: no tape

SEM, Inc.
 1555 Jefferson Road,
 Rochester, NY 14623
 Tel: +1 585-643-2000

SEM BELGIUM bv
 Schatting 73
 BE-8210 Zedelgem
 Belgium
 Tel. +32 59 56 02 70

Schlegel Electronic Materials Asia Limited
 Unit 1, 3/F, Block A
 New Trade Plaza
 6 On Ping Street
 Shatin, N.T., Hong Kong
 Tel: +852 2686 8168

BandSorb® SN

Ultra-thin, highly permeable EMI/RF absorber

Description:

BandSorb® SN series is an ultrathin near field noise suppression absorber used for EMI control in electronic devices. The absorber is designed for the frequency range from 10 MHz up to 6 GHz. It is used to mitigate EM energy, it interacts and suppresses the magnetic field at the noise source.

Availability:

BandSorb® SN series materials can be supplied in sheets as well as custom configurations, standard sheet size is 300 mm x 300 mm.
BandSorb® SN materials can be supplied with or without pressure sensitive adhesive (PSA).

Features and Benefits

High magnetic permeability.
RoHs, Halogen Free, Reach compliant

Applications

BandSorb® SN series absorber can be placed over CPUs, main chip sets and other memory and power IC devices to suppress radiated noise causing interference with RF functions, crosstalk or SAR emissions
It can be used to suppress noise currents from circuit trace lines and flat cables that act like radiating antennas causing EMI problems and crosstalk issues

Physical Properties :

Datasheet for Performance Characteristics					
CHARACTERISTICS	TEST	UNIT	SPECIFICATIONS		
SEM Elastomers absorber	-		SN-32	SN-120	SN-130
Typical Frequency Range	-	GHz	< 6	< 6	< 6
Typical Thicknesses	-	mm (inch)	0.1-1.0 (0.004-0.04)	0.1-0.5 (0.004-0.02)	0.1-0.3 (0.004-0.012)
Available Size		mm (inch)	300x20000/300x50000/200x300 (11.8x787.4/11.8x1968.5/7.87x11.8)		
Hardness	ASTM D 2240	Shore A	90	-	-
Elongation	ASTM D 412	%	35%		
Tensile Strength	ASTM D 412	MPa (psi)	3.1 (450)	5.6 (812)	5.6 (812)
Service Temperature	-	°C (°F)	-40 to 85 (-40 to 185)	-40 to 120 (-40 to 248)	-40 to 120 (-40 to 248)
Flammability Rating	UL94*	-	V2	V2	V2
Colour	-	-	Silver	Silver	Silver
Surface Resistivity	ASTM D 991	Ω-cm (Ω-in)	> 10 ¹² (>10 ¹²)	> 10 ⁶ (> 10 ⁶)	> 10 ⁶ (> 10 ⁶)
Compliance			2011/65/EU(RoHS 2.0) Compliance, REACH SVHC Compliance, Halogen free		

*Tested in accordance of UL94 specification

-The technical specification data is based on SEM tests and analysis that we believe to be reliable. However, in no event, shall SEM be liable for inaccuracies or omissions contained therein. In all cases, details and values should be verified by the customer

-UL is a registered trademark of Underwriters Laboratories, Inc.,

SEM, Inc.
1555 Jefferson Road,
Rochester, NY 14623
Tel: +1 585-643-2000

SEM BELGIUM bv
Schatting 73
BE-8210 Zedelgem
Belgium
Tel. +32 59 56 02 70

Schlegel Electronic Materials Asia Limited
Unit 1, 3/F, Block A
New Trade Plaza
6 On Ping Street
Shatin, N.T., Hong Kong
Tel: +852 2686 8168

Electromagnetic Properties

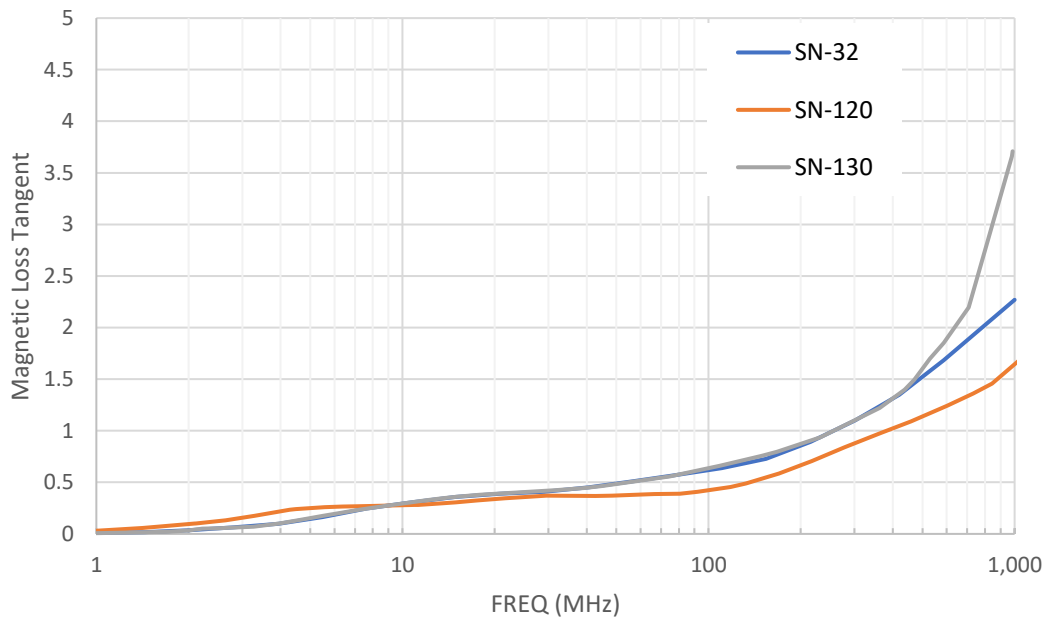
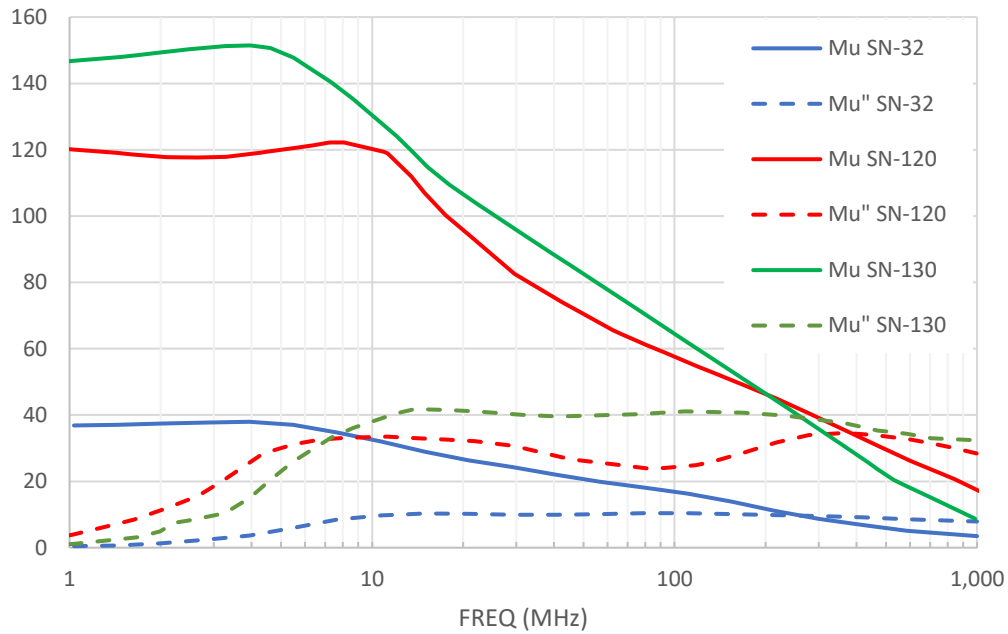

SEM, Inc.
 1555 Jefferson Road,
 Rochester, NY 14623
 Tel: +1 585-643-2000

SEM BELGIUM bv
 Schatting 73
 BE-8210 Zedelgem
 Belgium
 Tel. +32 59 56 02 70

Schlegel Electronic Materials Asia Limited
 Unit 1, 3/F, Block A
 New Trade Plaza
 6 On Ping Street
 Shatin, N.T., Hong Kong
 Tel: +852 2686 8168

Power loss & Transmission Attenuation Power ratio (Rtp)

The data are measured with IEC 62333 standard and calculated with the equations below:

$$\text{Transmission Attenuation Power Ratio (Rtp)} = -10 \log \left\{ \frac{10^{\frac{|S21|}{10}}}{(1 - 10^{\frac{|S11|}{10}})} \right\}$$

$$\text{Power loss} = 1 - \left(10 \times \frac{S11}{20}\right)^2 - \left(10 \times \frac{S21}{20}\right)^2$$

S21 and S11 are measured by the IEC 62333 microstrip line:

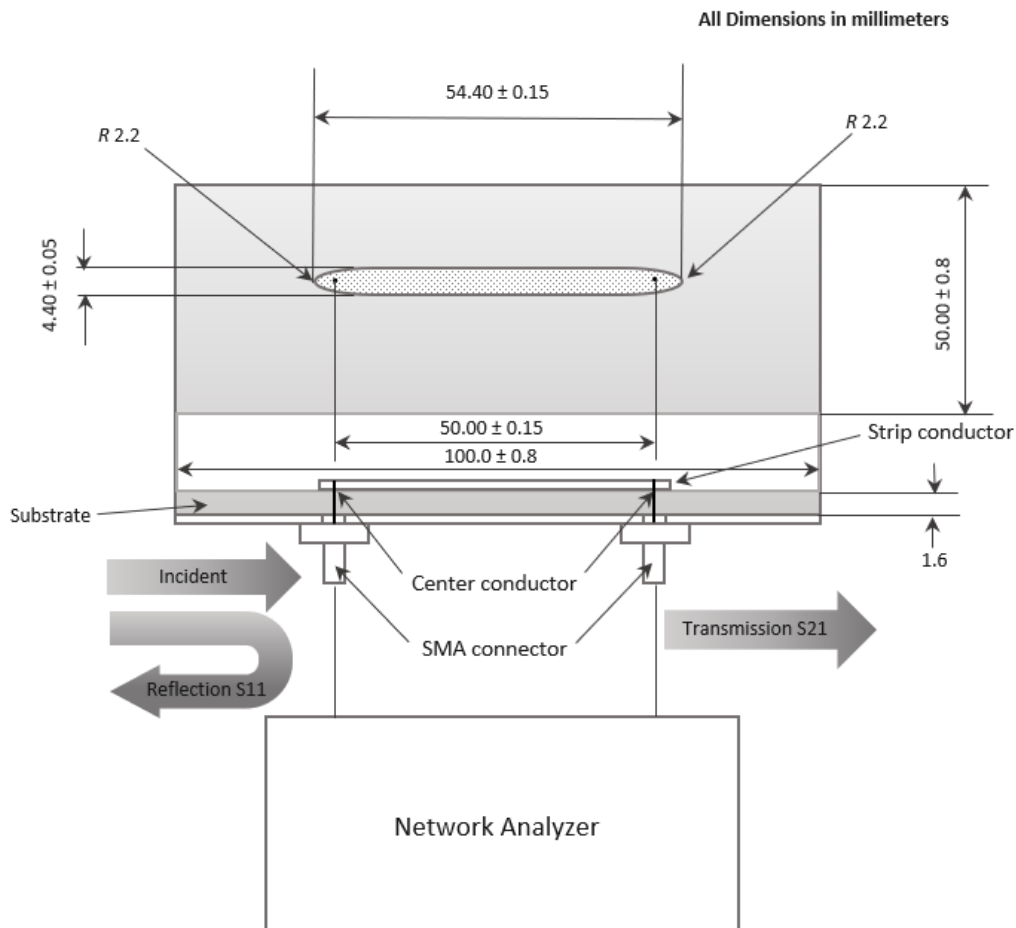

Result of 0.1 mmT samples

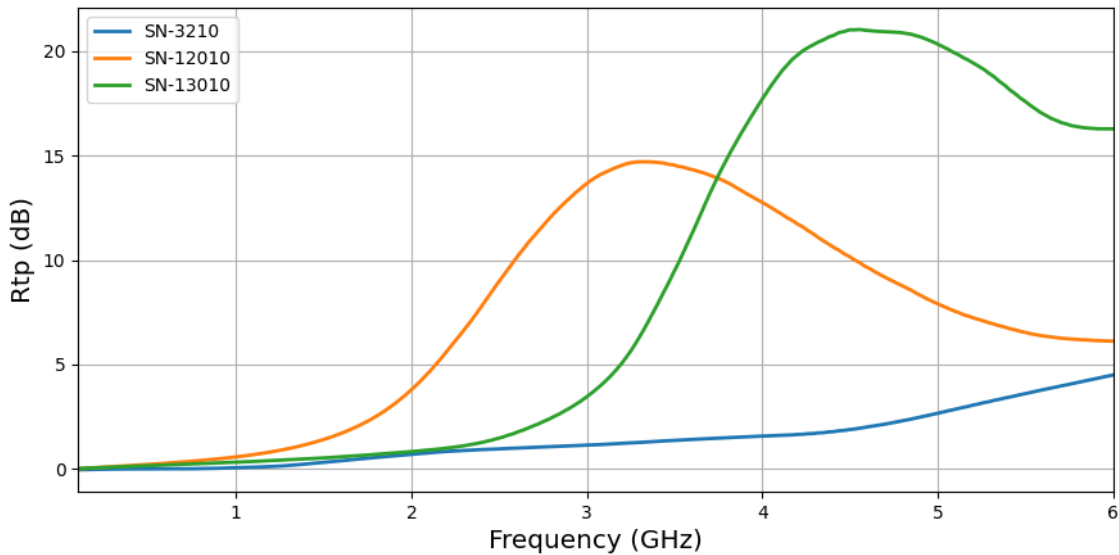
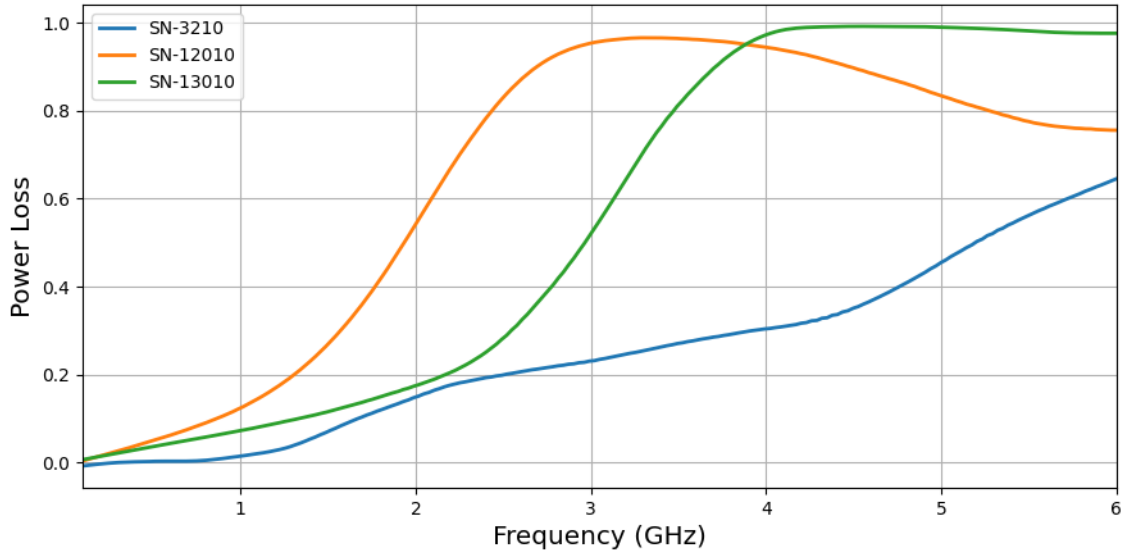

SEM, Inc.
 1555 Jefferson Road,
 Rochester, NY 14623
 Tel: +1 585-643-2000

SEM BELGIUM bv
 Schatting 73
 BE-8210 Zedelgem
 Belgium
 Tel. +32 59 56 02 70

Schlegel Electronic Materials Asia Limited
 Unit 1, 3/F, Block A
 New Trade Plaza
 6 On Ping Street
 Shatin, N.T., Hong Kong
 Tel: +852 2686 8168

Application example

Example 1 – To suppress noise reflected by casing and cross talk between substrates.

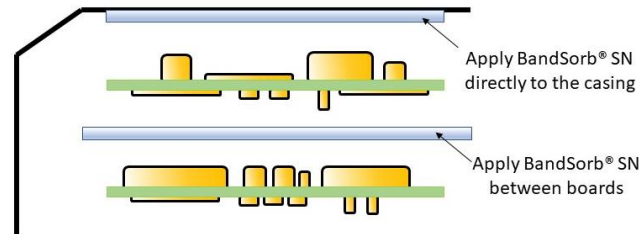

Example 2 – To suppress noise from cables.

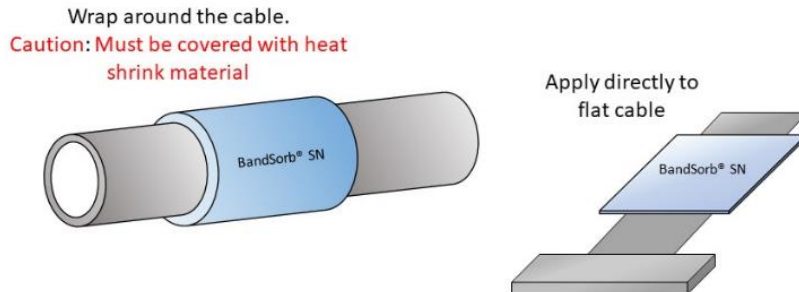

Example 3 – To suppress radiation noises from LSI and IC.

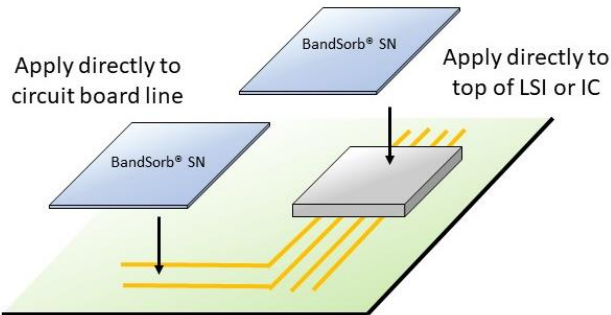

Example 4 – To suppress noise radiation (reflected noise) from the opening of shield or casing.

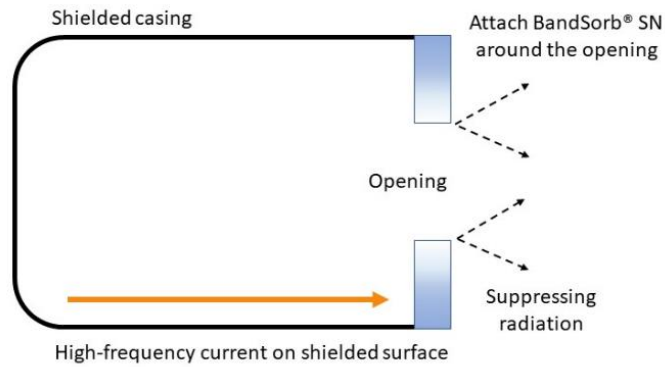

Part number system example

SN-	32	50	-	A
Product name	Mu@10MHz	thickness (0.5 mm)		PSA (blank: No PSA)

BandSorb® HP

Ferrite Sheets For NFC & Wireless Charging

Description:

BandSorb® HP series is a thin high permeability ferrite sheet designed to have low losses at 13.56 MHz. The high permeability makes it ideal to use for NFC, RFID application and wireless charging applications.

Availability:

BandSorb® HP series materials can be supplied in sheets and custom configurations; the standard sheet size is 125 mm x 125 mm. The BandSorb® HP consists of a ferrite material covered with a protective film on one side and adhesive tape on the other side.

Features and Benefits

High magnetic permeability, low loss
RoHs, Halogen Free

Applications

BandSorb® HP series can be used to improve the performance of:

- NFC antenna for mobile phones and automotive.
- NFC or RFID antenna for security & access control system.
- Wireless charging for mobile phones and battery powered handheld electronic devices

Physical Properties :

Datasheet for Performance Characteristics			
CHARACTERISTICS	TEST	UNIT	SPECIFICATIONS
BandSorb®	-	-	HP-150
Real Permeability	@13.56MHz, 0.1V	μ'	150
Imaginary Permeability	@13.56MHz, 0.1V	μ''	<5
Ferrite Thicknesses	-	mm (mil)	0.1 (3.9)
Typical Thicknesses	-	mm (mil)	0.15 (5.9)
Tensile Strength	ASTM D 1000	MPa (psi)	6.4 (928)
Service Temperature	-	°C (°F)	-25 to 120 (-13 to 248)
Flammability Rating	UL94*	-	V2
Colour	-	-	Black
Surface Resistivity	ASTM D 991	Ω-cm (Ω-in)	> 10 ⁹ (>10 ⁹)
Dielectric strength	-	V	400
Compliance	2011/65/EU(RoHS 2.0) Compliance, Halogen Free		

*Tested in accordance of UL94 specification

-The technical specification data is based on SEM tests and analysis that we believe to be reliable. However, in no event, shall SEM be liable for inaccuracies or omissions contained therein. In all cases, details and values should be verified by the customer

-UL is a registered trademark of Underwriters Laboratories, Inc.,

SEM, Inc.
1555 Jefferson Road,
Rochester, NY 14623
Tel: +1 585-643-2000

SEM BELGIUM bv
Schatting 73
BE-8210 Zedelgem
Belgium
Tel. +32 59 56 02 70

Schlegel Electronic Materials Asia Limited
Unit 1, 3/F, Block A
New Trade Plaza
6 On Ping Street
Shatin, N.T., Hong Kong
Tel: +852 2686 8168

Electromagnetic Properties

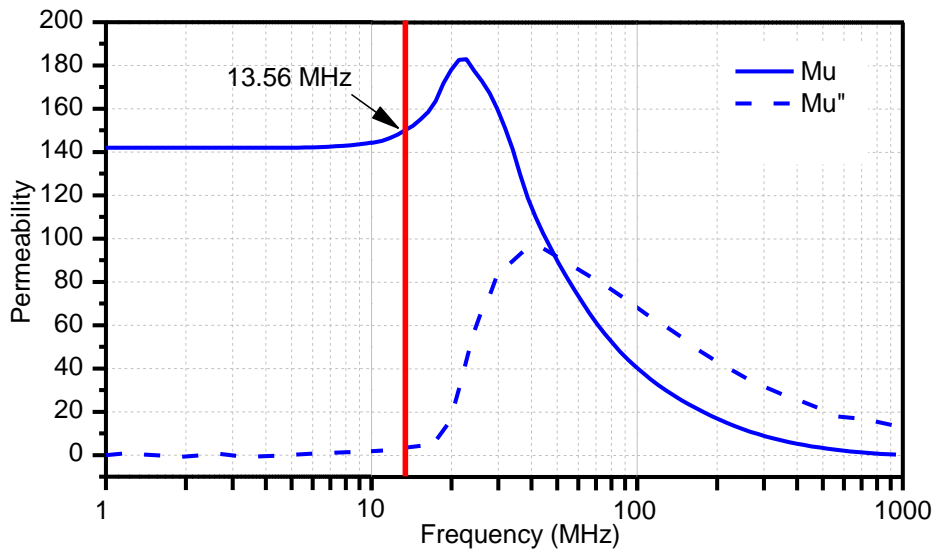

Structure

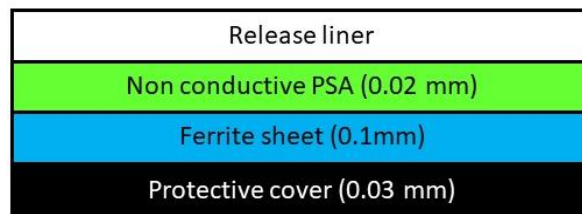

Application example

Example – Placing BandSorb® HP between the coil and the other components will suppress the formation of eddy current.

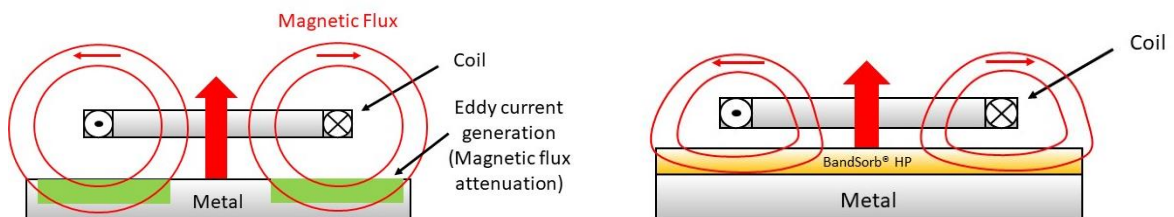

Part number system example

HP- 150 10 - 4040
 Product name permeability@13.56MHz thickness ferrite (0.1mm) Part Size code (40x40 mm)

SEM, Inc.
 1555 Jefferson Road,
 Rochester, NY 14623
 Tel: +1 585-643-2000

SEM BELGIUM bv
 Schatting 73
 BE-8210 Zedelgem
 Belgium
 Tel. +32 59 56 02 70

Schlegel Electronic Materials Asia Limited
 Unit 1, 3/F, Block A
 New Trade Plaza
 6 On Ping Street
 Shatin, N.T., Hong Kong
 Tel: +852 2686 8168

BandSorb® FB

Broadband Flexible Foam Sheet Absorber

Description:

BandSorb® FB is a lightweight high loss carbon impregnated dielectric foam absorber that provides a very low cost solution for many applications over the thinner, more expensive rubber absorbers. BandSorb® FB can be used for applications requiring absorption across a wide range of frequencies, such as antenna cross-talk, side lobe reduction, and cavity resonance suppression.

Availability:

BandSorb® FB series materials can be supplied in sheets as well as custom configurations. The standard sheet size is 610 mm x 610 mm. The BandSorb® FB consists out of carbon loaded polyurethane foam. BandSorb® FB is electrically conductive due to the use of the carbon dispersion.

Physical Properties :

Features and Benefits

Lightweight, flexible and easy to trim, High Loss, low density.
Available in different thicknesses to work in a wide range of broadband frequencies.

Applications

BandSorb® FB series can be used to

- Lower cavity Q's in RF amplifiers, oscillators, cabinets containing microwave devices, computer housings, LNB's.
- Isolation of antennas by Insertion loss, shrouding antennas to improve the antenna patterns and undesired back lobes
- Reduce surface currents on radiating elements and outer ground-plane type surfaces.
- Reflectivity of an object (metal or otherwise) can be reduced somewhat by applying one or more layers.

Datasheet for Performance Characteristics			
CHARACTERISTICS	TEST	UNIT	SPECIFICATIONS
Frequency Range	Insertion Loss	GHz	>1
Size	-	mm (inch)	610 x 610 (24x24)
Typical Thickness		mm (inch)	3.2 (1/8), 6.4 (1/4), 9.5 (3/8), 12.7 (1/2), 19.1 (3/4), 25.4 (1)
Maximum service Temperature	-	°C (°F)	100 (212)
Flammability Rating	UL94*	-	HF1
Compliance			2011/65/EU(RoHS 2.0) Compliance, REACH SVHC Compliance, Halogen free

Loading	Available Thickness (mm)					
	3.2	6.4	9.5	12.7	19.1	25.4
FB-18	✓	✓	✓	✓	✓	
FB-20	✓	✓	✓	✓	✓	
FB-22	✓	✓	✓	✓	✓	✓
FB-24	✓	✓	✓	✓	✓	✓
FB-26	✓	✓	✓	✓	✓	
FB-28	✓					
FB-30	✓	✓	✓	✓	✓	

SEM, Inc.
1555 Jefferson Road,
Rochester, NY 14623
Tel: +1 585-643-2000

SEM BELGIUM bv
Schatting 73
BE-8210 Zedelgem
Belgium
Tel. +32 59 56 02 70

Schlegel Electronic Materials Asia Limited
Unit 1, 3/F, Block A
New Trade Plaza
6 On Ping Street
Shatin, N.T., Hong Kong
Tel: +852 2686 8168

*Tested in according to UL94 specification

-The technical specification data is based on SEM tests and analysis that we believe to be reliable. However, in no event, shall SEM be liable for inaccuracies or omissions contained therein. In all cases, details and values should be verified by the customer

Electromagnetic Properties

BandSorb®	Attenuation (dB/cm)		Relative Impedance ($ Z /Z_0$)	
	3 GHz	10 GHz	3 GHz	10 GHz
FB-18	3.2	4.7	0.69	0.82
FB-20	4.2	7	0.61	0.78
FB-22	7.4	14.9	0.55	0.74
FB-24	11	24	0.25	0.44
FB-26	16	34	0.18	0.31
FB-28	20	40	0.16	0.27
FB-30	24	46	0.13	0.22

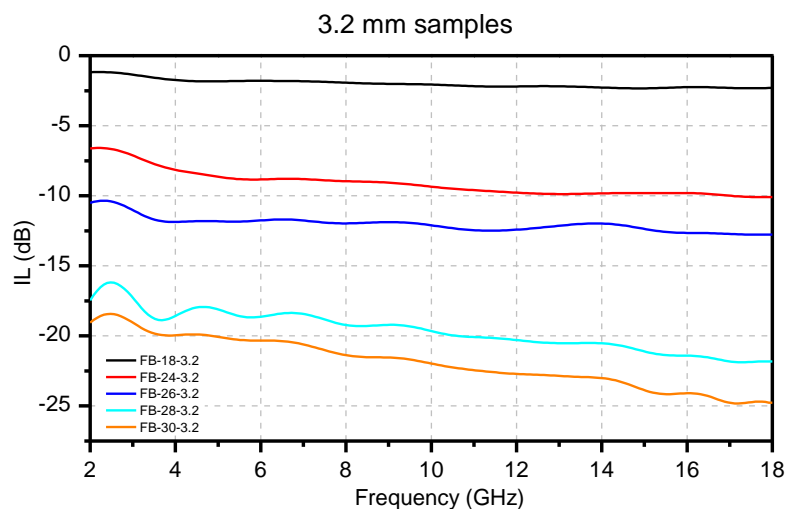
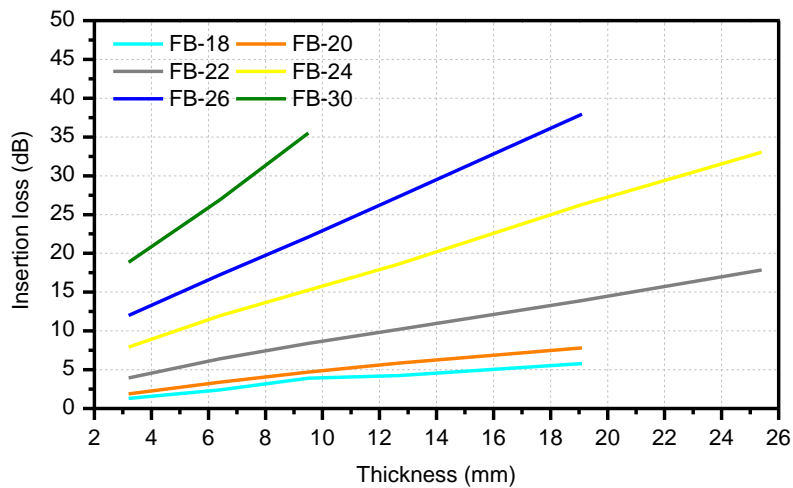

SEM, Inc.
1555 Jefferson Road,
Rochester, NY 14623
Tel: +1 585-643-2000

SEM BELGIUM bv
Schatting 73
BE-8210 Zedelgem
Belgium
Tel. +32 59 56 02 70

Schlegel Electronic Materials Asia Limited
Unit 1, 3/F, Block A
New Trade Plaza
6 On Ping Street
Shatin, N.T., Hong Kong
Tel: +852 2686 8168

Application example

Example 1 – Placing BandSorb® FB on the shroud (metal screen) of the antenna to improve the antenna patterns and undesired back lobes.

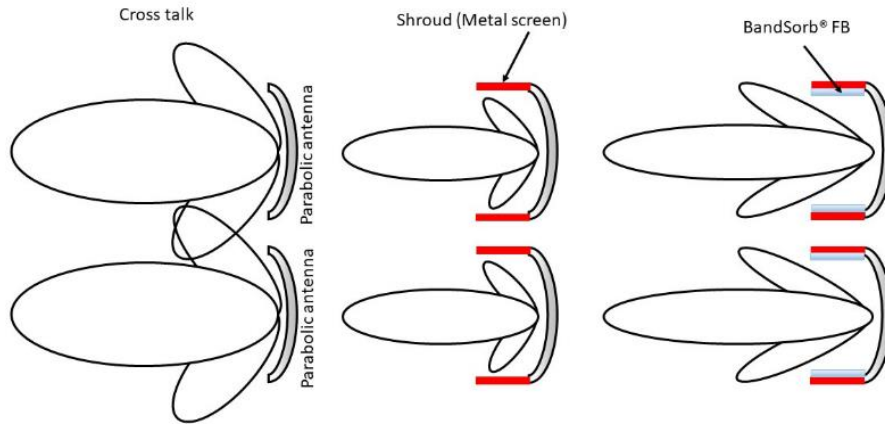

Example 2 – To suppress noise reflected by casing.

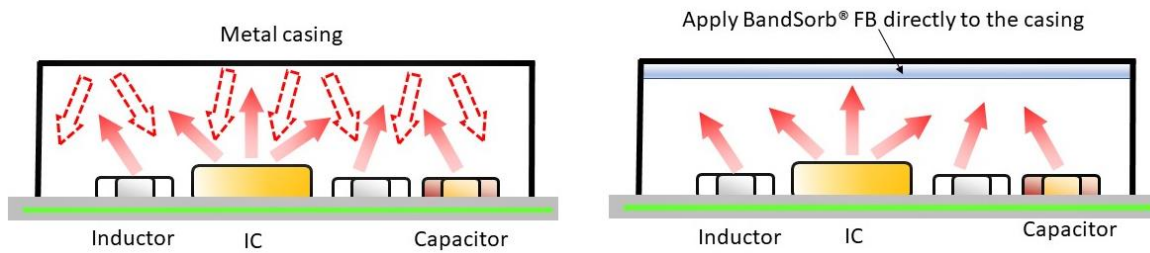

Instructions for use:

BandSorb® FB can be securely bonded to itself or to other materials such as metal, wood, and common plastic composites. To obtain a strong bond the surface should be thoroughly cleaned with a degreasing solvent. It can be readily cut with a band saw, scissors, or a sharp knife.

Part number system example

FB - 30 - 3.2 - A
 Product name Type Thickness with Pressure Sensitive Adhesive: A, blank: no tape

SEM, Inc.
 1555 Jefferson Road,
 Rochester, NY 14623
 Tel: +1 585-643-2000

SEM BELGIUM bv
 Schatting 73
 BE-8210 Zedelgem
 Belgium
 Tel. +32 59 56 02 70

Schlegel Electronic Materials Asia Limited
 Unit 1, 3/F, Block A
 New Trade Plaza
 6 On Ping Street
 Shatin, N.T., Hong Kong
 Tel: +852 2686 8168

BandSorb® SC/UC

Magnetically loaded, electrically non-conductive EMI/RF absorber

Description:

Schlegel's new range of elastomer Cavity resonance (BandSorb® SC/UC) Absorbers materials consists of a thin, flexible, high-loss, magnetically loaded, electrically non-conductive silicone rubber (SC) / silicone rubber (UC). Schlegel can provide this material with different configurations for use in the frequency range of 1 GHz up to millimeter waves. With our own dedicated manufacturing site and R & D team we can work closely with our customers to provide custom solutions where needed.

Availability:

We supply BandSorb® SC/UC series materials in sheets as well as custom die cut or kiss cut configurations. We can provide the BandSorb® SC/UC materials with or without pressure-sensitive adhesive (PSA). A myriad of options gives our customers flexibility when choosing which BandSorb® SC/UC product will work best in their design. BandSorb® SC/UC materials are available in standard thicknesses; however, we also offer custom sizes and thicknesses to suit your specific requirements.

Features and Benefits:

Dielectric and magnetic loaded.
RoHs, Halogen Free, Reach compliant.

Applications

BandSorb® SC/UC series provides a flexible solution that supports a wide range of EMI and RF suppression requirements.

Suppressing resonance and harmonics from circuitry, absorbing RF emissions from wiring, and reducing interference from internal peripheral devices are just a few examples of using BandSorb® SC/UC inside electronics housings such as computers, server racks and switches.

Designers can also use BandSorb® SC/UC series to reduce RF coupling between microwave components inside electronic housings. Typical applications include power amplifiers, oscillators and down/up converters.

When bonded to a metal surface, the BandSorb® SC/UC series will significantly reduce the reflectivity of metal objects or structures by absorbing microwave currents.

In the telecommunications market the material can be applied to antenna elements, microwave dishes, the inner or outer surfaces of waveguides for isolation, attenuation, or radiating patterns modifications. When applied to the side or even rear surfaces of certain objects, this material will cause a significant reduction in "head-on" reflectivity or backscattering.

BandSorb® SC/UC series can also be used for circuit-to-circuit EMI interference and reduction of unwanted emissions from the imaging CCD's and LCD displays.

In the automotive market, the BandSorb® SC/UC series can be used to suppress interference from onboard electronics, such as telematics and GPS circuitry.

Physical Properties:

Datasheet for Performance Characteristics								
CHARACTERISTICS	TEST	UNIT	SPECIFICATIONS					
SEM Elastomers absorber	-	-	SC-31	UC-31	SC-52	UC-52	SC-88	UC-88
Elastomer Binder	-	-	Silicone	PU	Silicone	PU	Silicone	PU
Typical Frequency Range	-	GHz	≥ 12		≥ 6		< 6	
Typical Thicknesses	-	mm (inch)	0.25 (0.01), 0.50 (0.02), 1.0 (0.04) and 1.5 (0.06)					
Typical Size	-	mm (inch)	300 x 300 (11.8 x 11.8)					
Hardness	ASTM D 2240	Shore A	65	75	75	85	87	90
Elongation	ASTM D 412	%	40	95	37	35	12	10
Tensile Strength	ASTM D 412	MPa (psi)	3.3 (479)	3.4 (493)	4.5 (653)	4.7 (682)	4.1 (595)	4.5 (653)
Maximum Service Temperature	-	°C (°F)	170 (338)	120 (248)	170 (338)	120 (248)	170 (338)	120 (248)
Flammability Rating	-	-	UL94 V0	/	UL94 V0	/	UL94 V0	/
Colour	-	-	Grey					
Surface Resistivity	ASTM D 991	Ω-cm (Ω-in)	> 10 ¹⁰ (> 4 x 10 ¹⁰)	> 10 ¹¹ (> 4 x 10 ¹¹)	> 10 ¹⁰ (> 4 x 10 ¹⁰)	> 10 ¹⁰ (> 4 x 10 ¹⁰)	> 10 ¹⁰ (> 4 x 10 ¹⁰)	> 10 ⁹ (> 4 x 10 ⁹)
Compliance	-	-	2011/65/EU(RoHS 2.0) Compliance, REACH SVHC Compliance, Halogen free					

-The technical specification data is based on SEM tests and analysis that we believe to be reliable. However, in no event, shall SEM be liable for inaccuracies or omissions contained therein. In all cases, details and values should be verified by the customer.

Electromagnetic Properties:

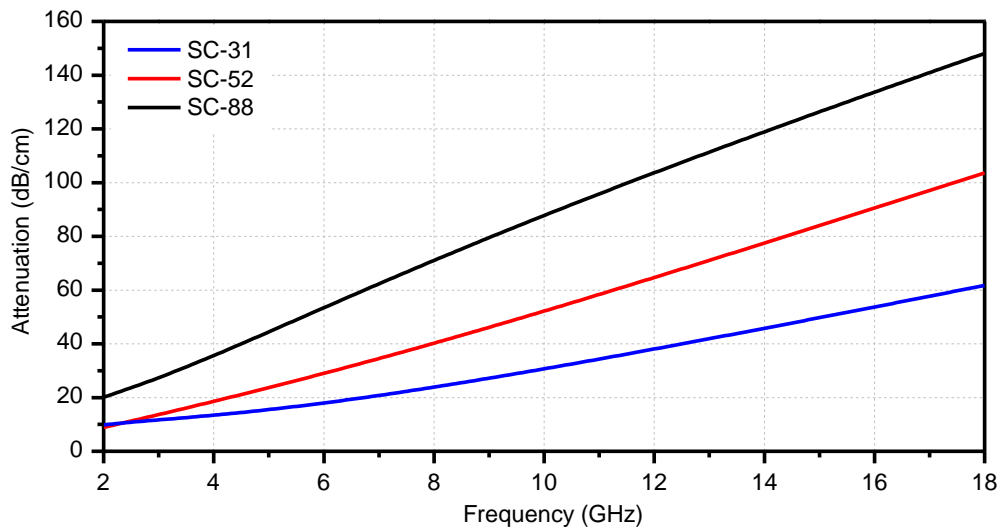

SEM, Inc.
1555 Jefferson Road,
Rochester, NY 14623
Tel: +1 585-643-2000

SEM BELGIUM bv
Schatting 73
BE-8210 Zedelgem
Belgium
Tel. +32 59 56 02 70

Schlegel Electronic Materials Asia Limited
Unit 1, 3/F, Block A
New Trade Plaza
6 On Ping Street
Shatin, N.T., Hong Kong
Tel: +852 2686 8168

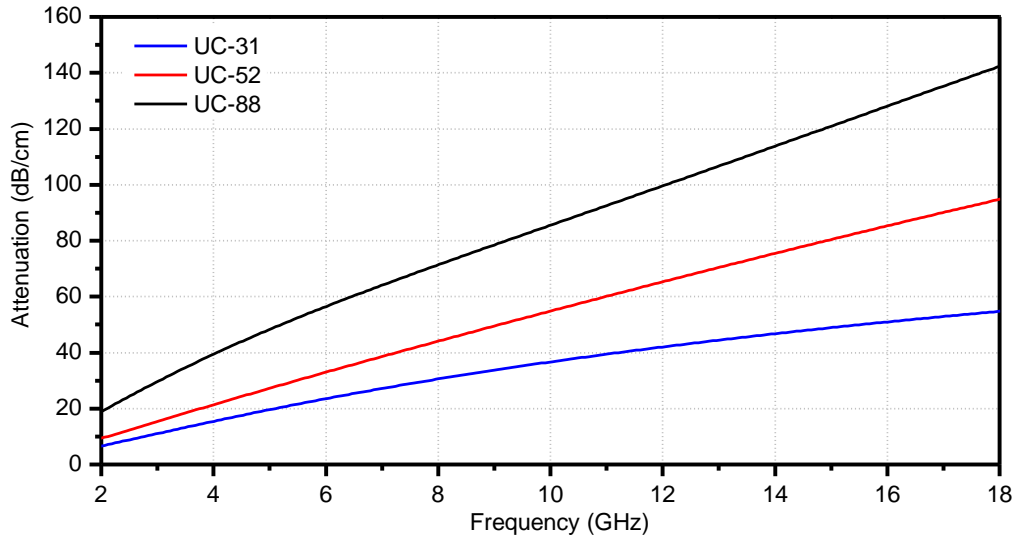

Application example

Example 1 – To suppress noise reflected by casing and cross talk between substrates.

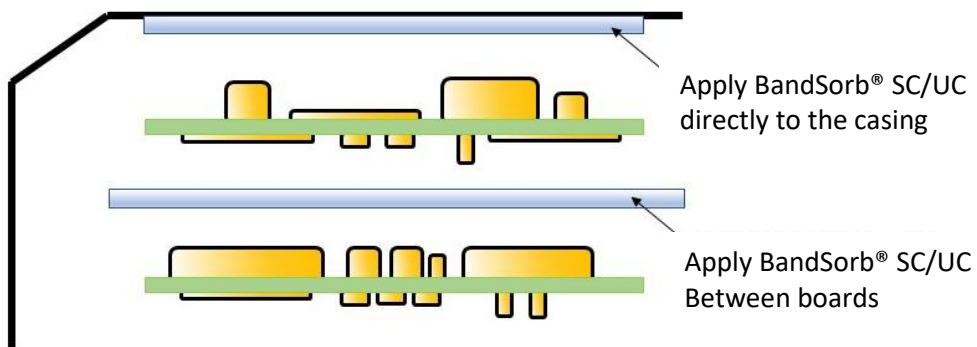

SEM, Inc.
 1555 Jefferson Road,
 Rochester, NY 14623
 Tel: +1 585-643-2000

SEM BELGIUM bv
 Schatting 73
 BE-8210 Zedelgem
 Belgium
 Tel. +32 59 56 02 70

Schlegel Electronic Materials Asia Limited
 Unit 1, 3/F, Block A
 New Trade Plaza
 6 On Ping Street
 Shatin, N.T., Hong Kong
 Tel: +852 2686 8168

Example 2 – To suppress noise radiation (reflected noise) from the opening of shield or casing.

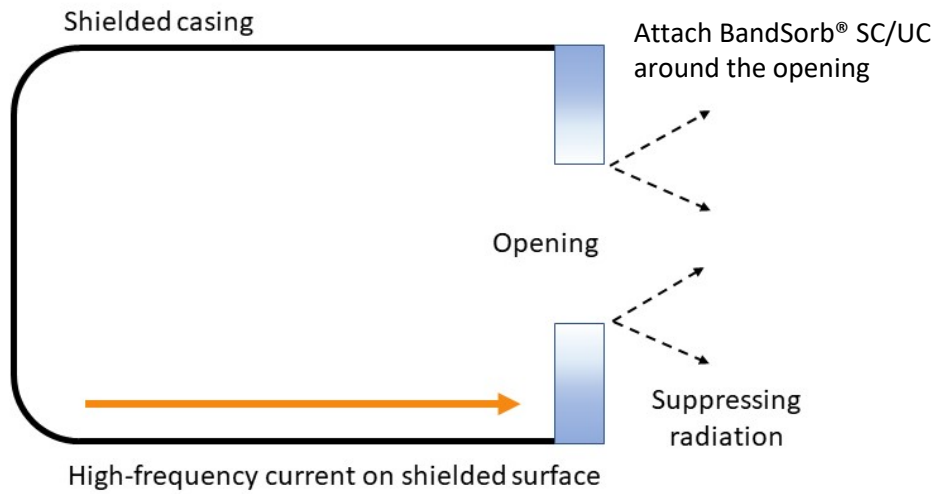

Part number system example

SC/UC	-	88	-	025	-	A
Product name		attenuation@10GHz		thickness (0.25 mm)		with Pressure Sensitive Adhesive: A, blank: no tape

BandSorb® ES

Machinable, Magnetically Loaded Epoxy Absorber Material

Description:

BandSorb® ES is a rigid, magnetically loaded epoxy material engineered for precision machining and optimized for microwave and RF applications. It is commonly used in RF loads, attenuators, waveguide terminations, and as a surface current suppressor on antenna elements. Bonding can be achieved using epoxy adhesives, and our technical team is available to assist in selecting the most appropriate adhesive for your application. For mechanical mounting, components can be supplied with pre-threaded holes for straightforward installation.

Availability:

BandSorb® ES is available in multiple grades (ES-6 to ES-140), each tailored to specific frequency ranges and attenuation requirements. Standard formats include:

- Flat Sheets: 305 x 305 mm, thicknesses from 6 mm to 75 mm
- Bars and Rods: Various diameters
- Custom Shapes: 3D geometries available upon request

Features and Benefits :

- Rigid and durable
- Easily machinable
- Customizable for specific RF applications

Applications

- Waveguide terminators
- Wall attenuators
- Strip lines and cavity absorbers
- Antenna array surface current suppression
- High-Q inductor cores (e.g., slug tuners)
- RF filters and free-space absorbers

Physical Properties :

Datasheet for Performance Characteristics			
CHARACTERISTICS	TEST	UNIT	SPECIFICATIONS
SEM Elastomers absorber	-		ES
Typical Frequency Range	-	GHz	≥ 1
Elastomer Binder	-	-	Epoxy
Density	-	g/cc	1.5 - 4.7
Hardness	ASTM D 2240	Shore D	>70
Thermal Expansion per °C	ASTM E 831	1/°C	<0.002
Thermal Conductivity	ASTM D 5470 (modified)	W/mK	0.47 - 1.65
Tensile Strength	ASTM D 412	MPa	>29
Maximum Service Temperature	-	°C (°F)	<180 (<356)
Color	-	-	Grey
Volume Resistivity	ASTM D 991	Ω-cm (Ω-in)	> 10 ¹⁰ (> 4 x 10 ⁹)
Water Absorption		% 24 hours	<0.3
Compliance			2011/65/EU(RoHS 2.0) Compliance, REACH SVHC Compliance, Halogen free

*Tested in according to UL94 specification

-The technical specification data is based on SEM tests and analysis that we believe to be reliable. However, in no event, shall SEM be liable for inaccuracies or omissions contained therein. In all cases, details and values should be verified by the customer

SEM, Inc.
1555 Jefferson Road,
Rochester, NY 14623
Tel: +1 585-643-2000

SEM BELGIUM bv
Schatting 73
BE-8210 Zedelgem
Belgium
Tel. +32 59 56 02 70

Schlegel Electronic Materials Asia Limited
Unit 1, 3/F, Block A
New Trade Plaza
6 On Ping Street
Shatin, N.T., Hong Kong
Tel: +852 2686 8168

Electromagnetic Properties:

**Bandsorb ES
 Typical Epsilon**

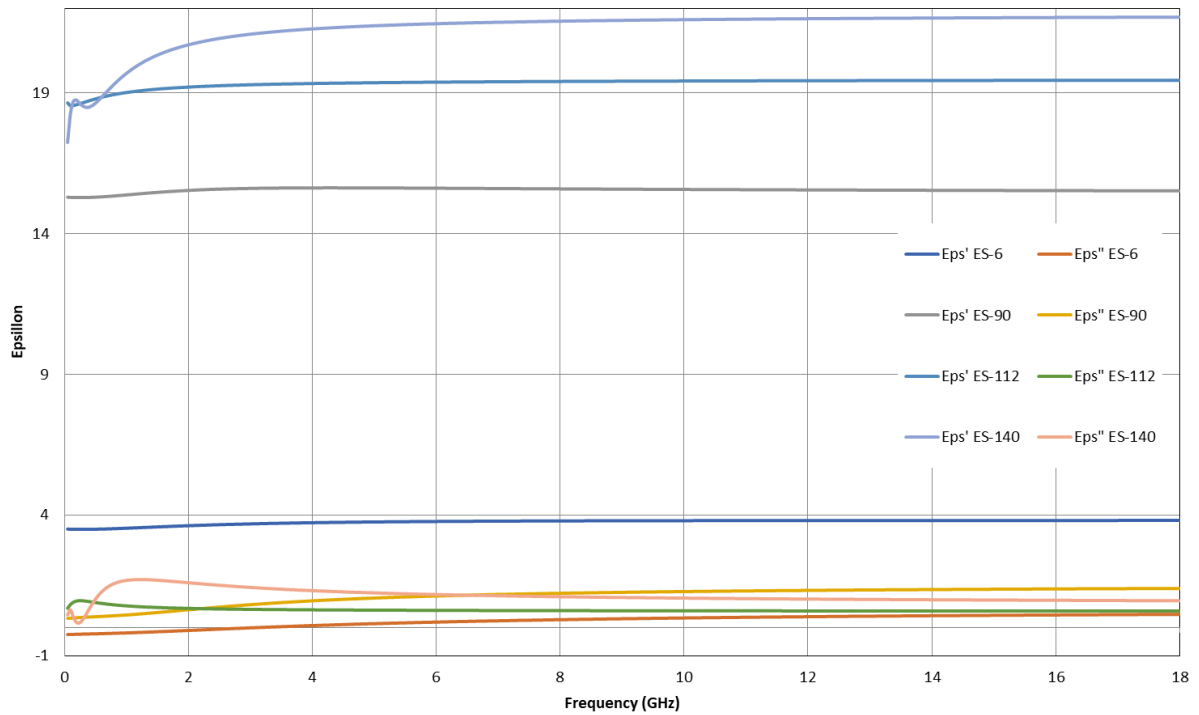

**Bandsorb ES
 Typical Mu**

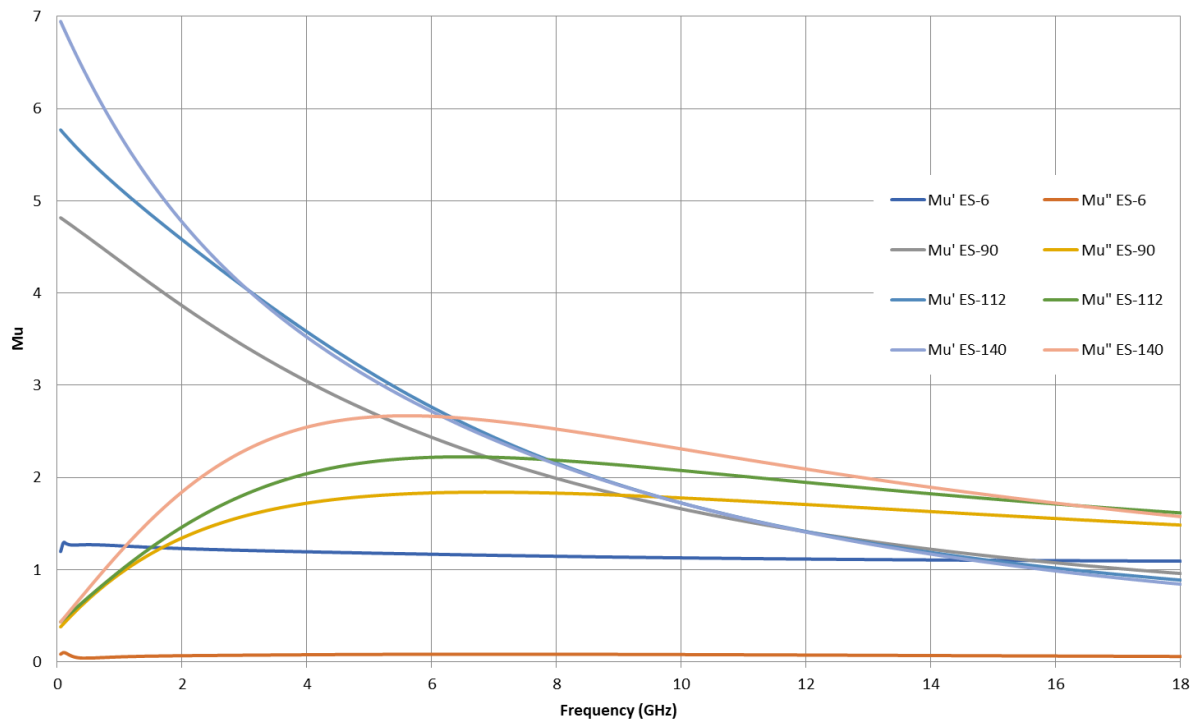

SEM, Inc.
 1555 Jefferson Road,
 Rochester, NY 14623
 Tel: +1 585-643-2000

SEM BELGIUM bv
 Schatting 73
 BE-8210 Zedelgem
 Belgium
 Tel. +32 59 56 02 70

Schlegel Electronic Materials Asia Limited
 Unit 1, 3/F, Block A
 New Trade Plaza
 6 On Ping Street
 Shatin, N.T., Hong Kong
 Tel: +852 2686 8168

Bandsorb ES
 Typical Attenuation

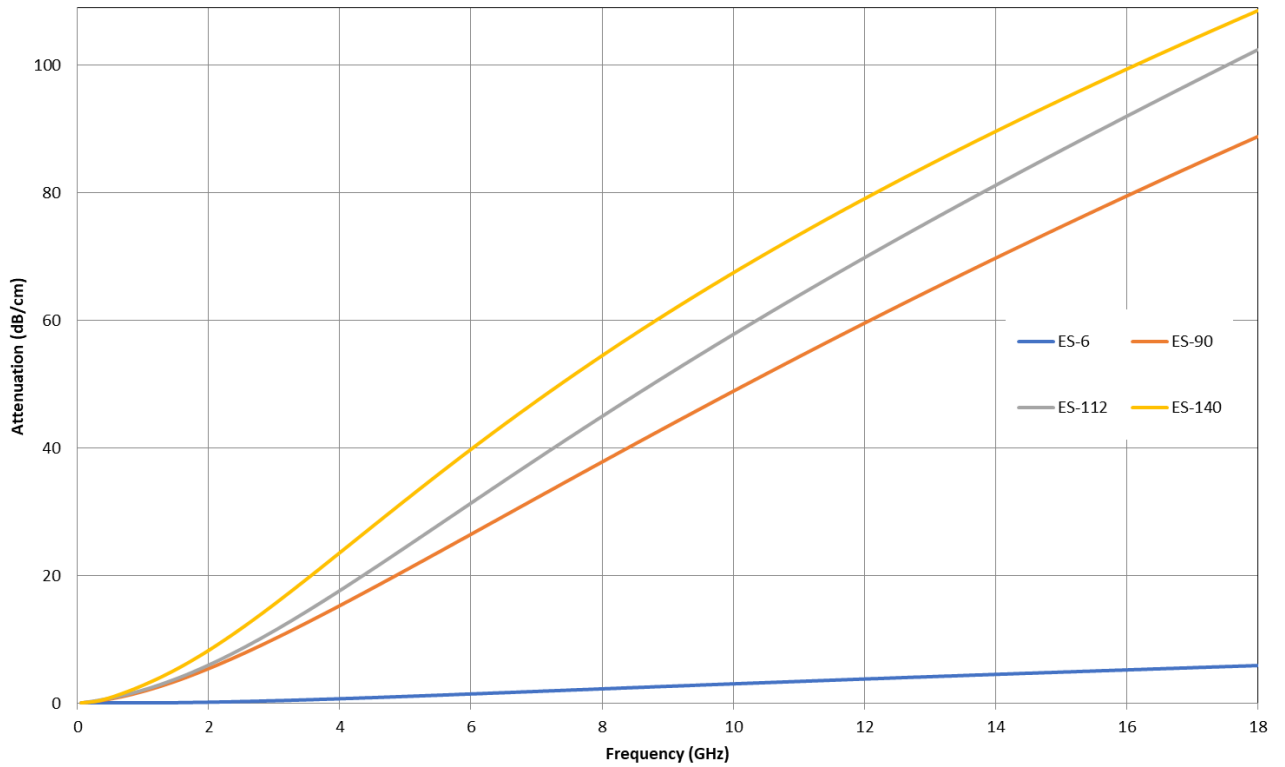

Bandsorb ES
 Typical Relative impedance

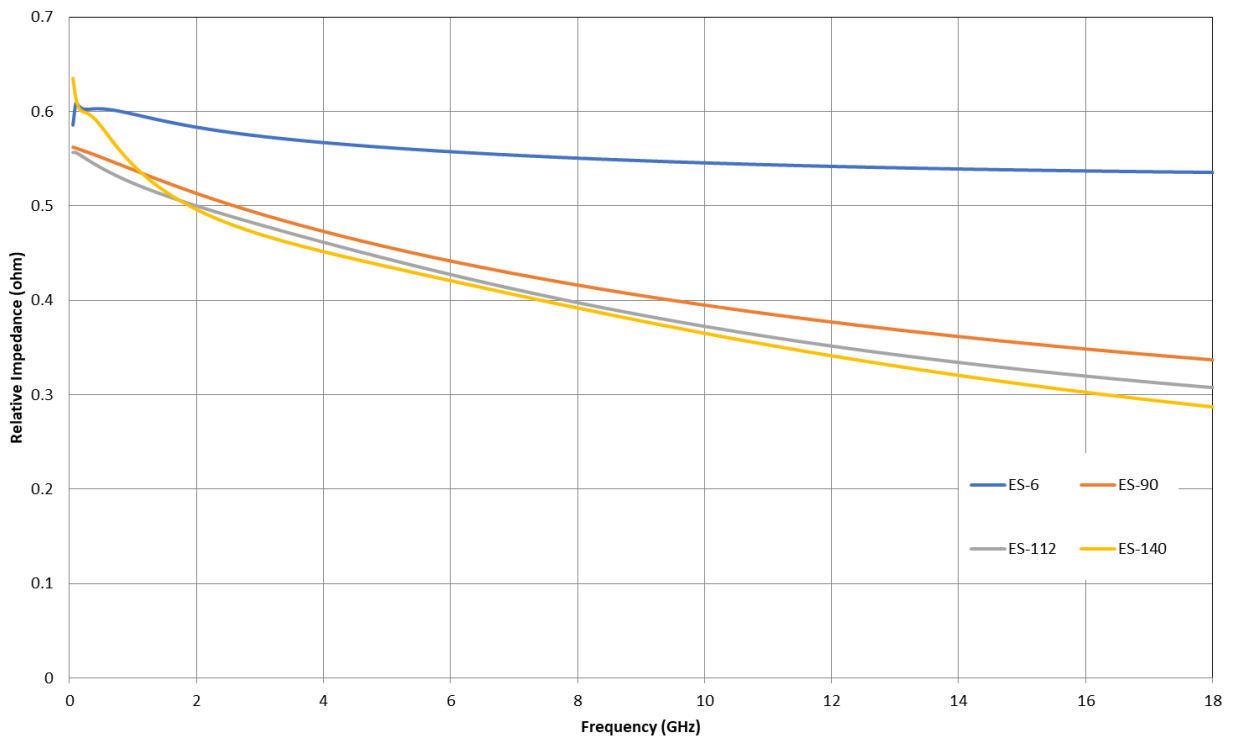

SEM, Inc.
 1555 Jefferson Road,
 Rochester, NY 14623
 Tel: +1 585-643-2000

SEM BELGIUM bv
 Schatting 73
 BE-8210 Zedelgem
 Belgium
 Tel. +32 59 56 02 70

Schlegel Electronic Materials Asia Limited
 Unit 1, 3/F, Block A
 New Trade Plaza
 6 On Ping Street
 Shatin, N.T., Hong Kong
 Tel: +852 2686 8168

Definitions and equations are detailed in the SEM EMI/RF Absorber Material Reference Guide, available upon request.

- ϵ' : Real part of dielectric epsilon
- ϵ'' : Imaginary part of dielectric epsilon
- μ' : Real part of magnetic permeability
- μ'' : Imaginary part of magnetic permeability
- dB/cm: Attenuation per unit length

The definition of dB/unit length is included in the reference, both in mathematical form and in words. The value is useful in comparing one material against another to determine which offers the most loss independent of interface reflection coefficients

- Z/Z_0 : Relative impedance (ideal match ≈ 1)

$|Z|/Z_0$, the normalized impedance magnitude ratio, can be used as a qualitative measure of the impedance match between free space and the material. An impedance ratio that is closest to 1 is the most desirable because at that ratio, the impedance match between the material and free space is perfect.

Important Notes:

- Dielectric constant (Epsilon') decreases with frequency
- Dielectric loss tangent typically decreases with frequency
- Magnetic loading increases from ES-6 to ES-140
- Nominal values provided; not suitable for procurement specifications
- Density is recommended for quality control over dielectric/magnetic measurements
- If specifications are needed, the customer should consult with the SEM Sales Department.

The use of dielectric/magnetic properties for Quality Control, i.e., incoming or outgoing inspection, is not recommended, because the measurement of these properties is very time consuming and complicated.

Part number system example

ES - 112
(Epoxy Structural)
Product name Load indication

Termination Design Considerations :

- ES-90 is the most commonly used grade and ideal for initial testing
- Step-tapered terminations: Suitable for narrow-band, single-frequency applications
- Uniformly tapered terminations: Preferred for wide-band applications due to low VSWR and dimensional tolerance
- Wall-type tapers: Recommended for high-power applications due to superior heat dissipation.