

DEFINING EMI SOLUTIONS

www.schlegelemi.com

NORTH AMERICA

Schlegel Electronic Materials, Inc.

1555 Jefferson Road,
Rochester, NY 14623
Tel No: +1 585-643 2000
Fax No: +1 585-427 7216
Email: schlegelemi.na@schlegelemi.com

EUROPE

Schlegel Electronic Materials, bv

Schatting 73,
8210 Zedelgem,
Belgium
Tel No: +32 59 560 270
Email: schlegelbe@schlegelemi.com

ASIA

Schlegel Electronic Materials Asia Limited

Unit 1, 3/F, Block A, New Trade Plaza,
6 On Ping Street, Shatin, N.T., Hong Kong
Tel No: +852-2686 8168
Fax No: +852-2686 8268
Email: schlegelemi@emeigroup.com

Schlegel (Dongguan) Electronics Limited

No. 8A Qiaoxin Road, Qiaotou, Dongguan,
Guangdong, China
Postal Code: 523525
Tel No: +86-769-8334 1628
Fax No: +86-769-8334 2028
Email: schlegelemi@emeigroup.com

Schlegel (Shanghai) Electronics Limited (Sales Office)

Room 402-02, Building 1-A,
Han's Science and Technology Center,
No. 199 Jinwan Road, Pudong New Area,
Shanghai, China
Postal Code: 201206
Tel No: +86-21-5868 3383
Fax No: +86-21-5868 3386
Email: schlegelemi@emeigroup.com

Taiwan Schlegel Electronics Limited (Sales Office)

No. 99, Alley 3, Lane 182, Section 2,
Wenhua Rd, Banqiao Dist. New Taipei City,
Taiwan R.O.C
Post Code : 22044
Tel No: +886-2-8258 5148
Fax No: +886-2-8258 5149
Email: schlegelemi@emeigroup.com



EMI-BeCu-Metals Fingerstock Gaskets

The mechanical spring characteristics of BeCu EMI Gaskets offer superior shielding effectiveness. These gaskets offer consistent performance and yield superb electrical spring contact within this industry.

Fingerstock

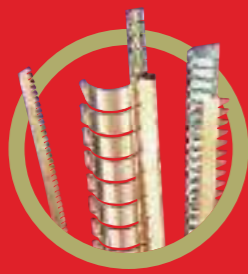

SEM'S FINGERSTOCK GASKETS

Think Schlegel EMI for Shielding

As the originator of the fabric clad foam EMI shielding technology, Schlegel EMI is the industry's most trusted name. We continue to set the standard for quality and innovation, designing advanced solutions for a wide range of applications. And our worldwide locations ensure that you get what you need, when and where you need it.

Modern electronic equipment often requires EMI Gaskets to avoid radiating EMI/RFI and to prevent susceptibility to outside sources of EMI/RFI.

Maintaining electromagnetic compatibility can be an increasing challenge for the designers of today's electronic and electrical products. Schlegel Electronic Materials, Inc. (SEM), the preeminent manufacturer of fabric over foam EMI shielding products for the computer, telecommunications, and electronics industries, offers a full range of EMI shielding products-including gaskets, I/O backplane shielding gaskets, and highly conductive envelopes, tapes and laminates. SEM is now proud to introduce a complete line of quality beryllium copper (BeCu) EMI Gaskets. The addition of BeCu Gaskets to SEM's extensive portfolio of shielding products allows SEM to be your exclusive EMI shielding supplier, to help you meet or exceed your global requirements for electromagnetic compatibility (EMC).

The mechanical spring characteristics of BeCu EMI Gaskets offer superior shielding effectiveness. These gaskets offer consistent performance and yield superb electrical spring contact within this industry.

SEM provides all the popular standard styles and sizes of BeCu gaskets. These gaskets operate in spaces from .010 inches up to .500 inches. SEM also offers many styles of soft gaskets that provide the low compression force needed in many applications. Custom spring contacts and gaskets are also available.

Table of Contents

Introduction.....	2
Low Profile & PCI Series Gaskets	4
Adhesive Mount (AH) and Dome Top (DT, D) Series Gaskets	5
Dome Top Solid Series (DTS) and Slot Mount Series Gaskets	6
Slot Mount Series Gaskets (RH)	7
Slot Mount Series Gaskets (AT)	8
Folded Series Gaskets (FS, FSH)	9
Folded Series Gaskets (FSC, FSV)	10
Folded Series Gaskets (FSD)	11
Twist Series (T, TV)	12
Twist Series (T2, UT, UT3)	13
Clip-On Series Gaskets	14-18
Contact Series	19-21
Pin D Connectors	22-25
Application of Fingerstock Gaskets	26
Ordering Information & Adhesive Mounting of EMI Gaskets	27
Metals Galvanic Compatibility Chart	28
Compression / Deflection Performance	29

Low Profile & PCI Series GASKETS

Low Profile Adhesive Mount

Black = inches Red = mm

SEM P/N	A	B	FINGER	PITCH	MAT. THICK	LENGTH	FINGERS	TAPE						
TAHLP0845X16	.08	2.03	.45	11.43	.100	2.54	.125	3.18	.004	.102	16	406	128	.145
TAHLP845X16	.08	2.03	.45	11.43	.100	2.54	.125	3.18	.003	.076	16	406	128	.145
TAHLP0126X16	.12	3.05	.60	15.24	.100	2.54	.125	3.18	.004	.102	16	406	128	.200
TAHLP8126X16	.12	3.05	.60	15.24	.100	2.54	.125	3.18	.003	.076	16	406	128	.200



MOUNTING OPTIONS

- Tape

The low profile series gaskets incorporate design features that allow for some of the lowest compression forces in the industry, while achieving high performance shielding effectiveness. These gaskets are ideally suited for small aperture applications.

X - Select material/finish (see page 27)

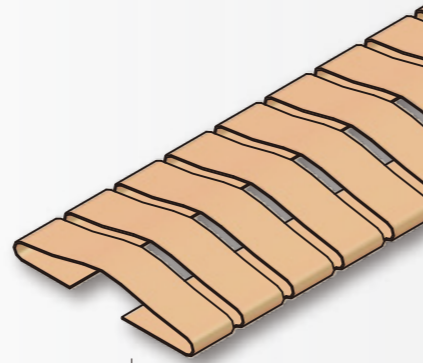
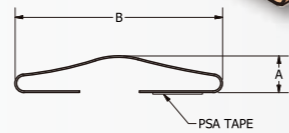

Low Profile Hook

Black = inches Red = mm

SEM P/N	A	B	FINGER	PITCH	MAT. THICK	LENGTH	FINGERS	HOOK ID	TAPE						
THLP0645X16	.06	1.52	.45	11.43	.100	2.54	.125	3.18	.004	.102	16	406	128	.060	.145
THLP845X16	.06	1.52	.45	11.43	.100	2.54	.125	3.18	.003	.076	16	406	128	.060	.145



MOUNTING OPTIONS

- Tape

X - Select material/finish (see page 27)

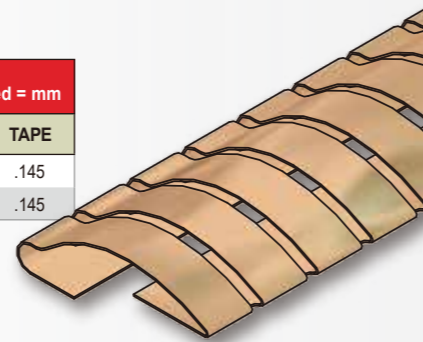
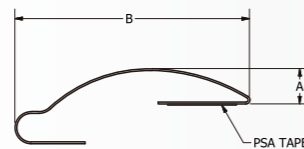

High performance Compact PCI Gaskets designed for easy card insertion in rack mount applications. This gasket is available in two different sizes to accommodate different customer extrusions. They are available in both Beryllium Copper and Stainless Steel.

PCI Series

Black = inches Red = mm

SEM P/N	A	B	C	D	FINGER	PITCH	MAT. THICK	LENGTH	FINGERS								
TPCI0719X4.6	.07	1.78	.18	4.57	.05	1.27	.01	.25	.180	4.57	.200	5.08	.002	.051	4.60	117	23
TPCI0719X9.0	.07	1.78	.18	4.57	.05	1.27	.01	.25	.180	4.57	.200	5.08	.002	.051	9.00	229	45
TPCI0719X14.4	.07	1.78	.18	4.57	.05	1.27	.01	.25	.180	4.57	.200	5.08	.002	.051	14.40	366	72
TPCIS719X4.6	.07	1.78	.18	4.57	.05	1.27	.01	.25	.180	4.57	.200	5.08	.002	.051	4.60	117	23
TPCIS719X9.0	.07	1.78	.18	4.57	.05	1.27	.01	.25	.180	4.57	.200	5.08	.002	.051	9.00	229	45
TPCIS719X14.4	.07	1.78	.18	4.57	.05	1.27	.01	.25	.180	4.57	.200	5.08	.002	.051	14.40	366	72
TPCI0819X4.6	.07	1.78	.19	4.83	.05	1.27	.02	.51	.180	4.57	.200	5.08	.002	.051	4.60	117	23
TPCI0819X9.0	.07	1.78	.19	4.83	.05	1.27	.02	.51	.180	4.57	.200	5.08	.002	.051	9.00	229	45
TPCI0819X14.4	.07	1.78	.19	4.83	.05	1.27	.02	.51	.180	4.57	.200	5.08	.002	.051	14.40	366	72
TPCIS819X4.6	.07	1.78	.19	4.83	.05	1.27	.02	.51	.180	4.57	.200	5.08	.002	.051	4.60	117	23
TPCIS819X9.0	.07	1.78	.19	4.83	.05	1.27	.02	.51	.180	4.57	.200	5.08	.002	.051	9.00	229	45
TPCIS819X14.4	.07	1.78	.19	4.83	.05	1.27	.02	.51	.180	4.57	.200	5.08	.002	.051	14.40	366	72



MOUNTING OPTIONS

- Extrusion

X - Select material/finish (see page 27)

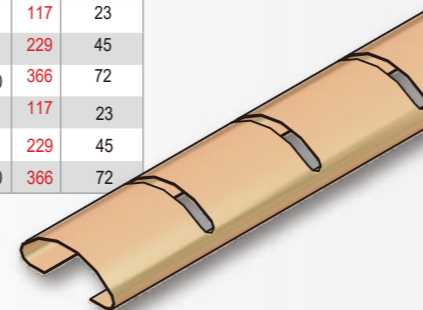
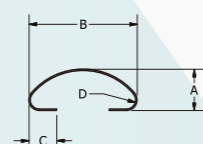

Adhesive Mount & Dome Top Series GASKETS

Adhesive Mount Series AH

Black = inches Red = mm Comp = Compressed

SEM P/N	A	B	C	FINGER	PITCH	MAT. THICK	COMP WIDTH	COMP HEIGHT	LENGTH	FINGERS	TAPE									
TAH01132X16	.11	2.79	.32	8.13	.20	5.08	.170	4.32	.187	4.75	.003	.076	.39	9.91	.04	1.02	16	406	86	.145
TAHS1132X16	.11	2.79	.32	8.13	.20	5.08	.170	4.32	.187	4.75	.002	.051	.39	9.91	.04	1.02	16	406	86	.145
TAH01337X16	.13	3.30	.37	9.40	.21	5.33	.225	5.72	.250	6.35	.003	.076	.51	12.95	.05	1.27	16	406	64	.145
TAHS1337X16	.13	3.30	.37	9.40	.21	5.33	.225	5.72	.250	6.35	.002	.051	.51	12.95	.05	1.27	16	406	64	.145
TAH01438X16	.14	3.56	.38	9.65	.20	5.08	.343	8.71	.375	9.53	.004	.102	.53	13.46	.05	1.27	16	406	43	.145
TAH02260X16	.22	5.59	.60	15.24	.28	7.11	.344	8.74	.375	9.53	.005	.127	.73	18.54	.09	2.29	16	406	43	.200
TAHS2260X16	.22	5.59	.60	15.24	.28	7.11	.344	8.74	.375	9.53	.003	.076	.73	18.54	.09	2.29	16	406	43	.200
TAH03278X16	.32	8.13	.78	19.81	.45	11.43	.344	8.74	.375	9.53	.004	.102	.98	24.89	.12	3.05	16	406	43	.375
TAHS3278X16	.32	8.13	.78	19.81	.45	11.43	.344	8.74	.375	9.53	.003	.076	.98	24.89	.12	3.05	16	406	43	.375



MOUNTING OPTIONS

- Tape

The AH series gaskets are adhesive mounted general-purpose gaskets used in both compression and wiping applications. Sizes range from .11" (2.8mm) to .32" (8.1mm) in height. Applications include electronic enclosures, shielded cabinets, and MRI chamber doors.

X - Select material/finish (see page 27)

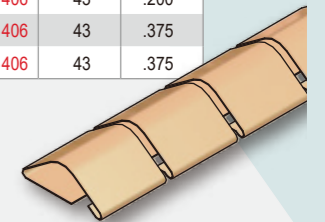
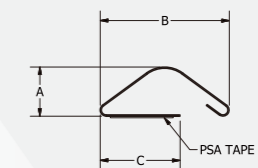

The Dome Top Gaskets are known for their large surface area for electrical contact and smooth wiping action. Also available in a solid top profile allowing for omni-directional wiping. Together with the Slot Mount Series, the Dome Top Gaskets are a mainstay in the enclosure/chassis industries. Commonly mounted with adhesive tape.

Dome Top Series DT

Black = inches Red = mm Comp = Compressed

SEM P/N	A	B	FINGER	PITCH	MAT. THICK	COMP WIDTH	COMP HEIGHT	LENGTH	FINGERS	TAPE								
TDT01135X15	.11	2.79	.35	8.89	.169	4.29	.187	4.75	.003	.076	.38	9.65	.06	1.52	15	381	80	.100
TDT81135X15	.11	2.79	.35	8.89	.169	4.29	.187	4.75	.002	.051	.38	9.65	.06	1.52	15	381	80	.100
TDT01445X15	.14	3.56	.45	11.43	.228	5.79	.250	6.35	.003	.076	.51	12.95	.07	1.78	15	381	60	.100
TDT81445X15	.14	3.56	.45	11.43	.228	5.79	.250	6.35	.002	.051	.51	12.95	.07	1.78	15	381	60	.100
TDT02262X15	.22	5.59	.62	15.75	.345	8.76	.375	9.53	.004	.102	.76	19.30	.10	2.54	15	381	40	.200
TDT82262X15	.22	5.59	.62	15.75	.345	8.76	.375	9.53	.003	.076	.76	19.30	.10	2.54	15	381	40	.200



MOUNTING OPTIONS

- Tape

The Dome Top gaskets have fully independent fingers that are adhesive mounted. Their smooth curve provides a large area for electrical contact and smooth wiping action.

X - Select material/finish (see page 27)

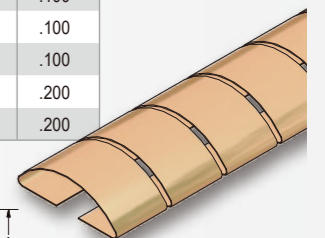
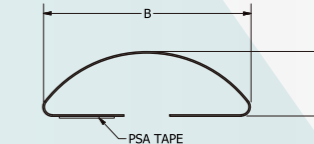

Dome Top Series D

Black = inches Red = mm

SEM P/N	A	B	C	D	E	FINGER	PITCH	MAT. THICK	LENGTH	FINGERS									
*TDA01135 X16	.11	2.80	.35	8.90	.15	3.70	.090	2.3	.020	.510	.17	4.29	.19	4.75	.003	.08	16	408.04	86



MOUNTING OPTIONS

- Tape

X - Select material/finish (see page 27)

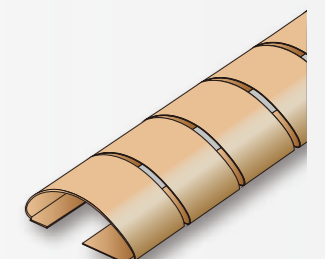
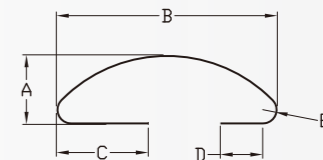

Other dimensions available upon request, please contact your SEM representative.

Dome Top Solid Series DTS														Black = inches		Red = mm		Comp = Compress	
SEM P/N	A		B		FINGER		PITCH		MAT. THICK		COMP WIDTH		COMP HEIGHT		LENGTH	FINGERS	TAPE		
TDS01135X15	.11	2.79	.35	8.89	.169	4.29	.187	4.75	.003	.076	.38	9.65	.06	1.52	15	381	80	.100	
TDSS1135X15	.11	2.79	.35	8.89	.169	4.29	.187	4.75	.002	.051	.38	9.65	.06	1.52	15	381	80	.100	
TDS01445X15	.14	3.56	.45	11.43	.250	6.35	.250	6.35	.003	.076	.51	12.95	.07	1.78	15	381	60	.100	
TDSS1445X15	.14	3.56	.45	11.43	.250	6.35	.250	6.35	.002	.051	.51	12.95	.07	1.78	15	381	60	.100	
TDS02262X15	.22	5.59	.62	15.75	.345	8.76	.375	9.53	.004	.102	.76	19.30	.10	2.54	15	381	40	.200	
TDSS2262X15	.22	5.59	.62	15.75	.345	8.76	.375	9.53	.003	.076	.76	19.30	.10	2.54	15	381	40	.200	



MOUNTING OPTIONS
 ■ Tape
 The Dome Top "Solid" Series gaskets have a strip that connects each finger along the top. This allows for unique angular wiping action without snagging. Other features are the same as the Dome Top Series.
 X - Select material/finish (see page 27)

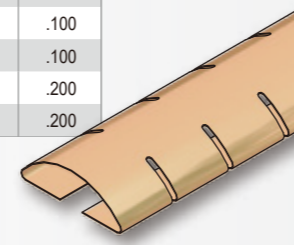
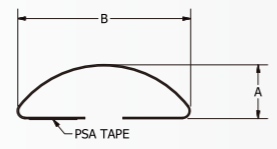

Slot Mount Series GASKETS

Slot mount gaskets are a standard in the electronic enclosure industry. These gaskets are used in shorter lengths as ESD contacts and longer lengths as EMI gaskets, which clip into slots or slide onto mounted tracks.

Alternate Finger Slot Mount														Black = inches		Red = mm							
SEM P/N	A		B		C		D		*E	*F	*G	FINGER	PITCH	MAT. THICK	LENGTH	FINGERS							
TAF01132X16	.11	2.79	.32	8.13	.09	2.16	.02	.51	.09	2.29	.26	6.60	.04	1.02	.169	4.29	.187	4.75	.003	.089	16	406	85
*TAF01132X16	.11	2.80	.32	8.13	.09	2.16	.02	.51	-	-	-	-	-	-	.169	4.29	.187	4.75	.003	.08	16	403.29	85
*TAFB1132X16	.11	2.80	.32	8.13	.09	2.16	.02	.51	-	-	-	-	-	-	.169	4.29	.187	4.75	.002	.06	16	403.29	85
TAF301132X16	.11	2.79	.32	8.13	.08	2.03	.02	.51	.09	2.29	.26	6.60	.04	1.02	.169	4.29	.187	4.75	.004	.102	16	406	85
*TAF3T1132X16	.11	2.80	.32	8.13	.09	2.16	.02	.51	-	-	-	-	-	-	.169	4.29	.187	4.75	.003	.08	16	403.29	85
TAF401132X16	.11	2.79	.32	8.13	.08	2.03	.02	.51	.09	2.29	.26	6.60	.04	1.02	.169	4.29	.187	4.75	.004	.102	16	406	85
TAFS1132X16	.11	2.79	.32	8.13	.09	2.16	.02	.51	.09	2.29	.26	6.60	.04	1.02	.169	4.29	.187	4.75	.002	.06	16	406	85
TAF3S1132X16	.11	2.79	.32	8.13	.08	2.03	.02	.51	.09	2.29	.26	6.60	.04	1.02	.169	4.29	.187	4.75	.002	.051	16	406	85
TAF4S1132X16	.11	2.79	.32	8.13	.08	2.03	.02	.51	.09	2.29	.26	6.60	.04	1.02	.169	4.29	.187	4.75	.002	.051	16	406	85
TAF02260X16	.22	5.59	.60	15.24	.14	3.56	.04	1.02	.14	3.56	.52	13.21	.07	1.78	.250	6.35	.282	7.16	.005	.127	16	406	57
*TAF02260X16	.22	5.59	.60	15.24	.13	3.30	.04	1.02	-	-	-	-	-	-	.250	6.35	.282	7.16	.005	.127	16	407.3	57
TAF302260X16	.22	5.59	.60	15.24	.14	3.56	.04	1.02	.14	3.56	.52	13.21	.07	1.78	.250	6.35	.282	7.16	.003	.076	16	406	58
TAFS2260X16	.22	5.59	.60	15.24	.14	3.56	.04	1.02	.14	3.56	.52	13.21	.07	1.78	.250	6.35	.282	7.16	.003	.076	16	406	57
TAF3S2260X16	.22	5.59	.60	15.24	.14	3.56	.04	1.02	.14	3.56	.52	13.21	.07	1.78	.250	6.35	.282	7.16	.003	.076	16	406	58
*TAF01337X16	.13	3.30	.37	9.40	.09	2.16	.02	.51	-	-	-	-	-	-	.226	5.75	.25	6.35	.003	.08	16	405.8	64
*TAFB1537X059	.15	3.70	.37	9.40	.09	2.16	.02	.51	-	-	-	-	-	-	.177	4.50	.205	5.2	.003	.08	.59	14.9	3
*TAF01537X059	.15	3.70	.37	9.40	.09	2.16	.02	.51	-	-	-	-	-	-	.177	4.50	.205	5.2	.002	.06	.59	14.9	3
*TAFD1537X059	.15	3.70	.37	9.40	.09	2.16	.02	.51	-	-	-	-	-	-	.177	4.50	.205	5.2	.004	.1	.59	14.9	3
*TAF01132X054	.11	2.80	.32	8.13	.09	2.16	.02	.51	-	-	-	-	-	-	.169	4.29	.187	4.75	.003	.08	.54	13.79	3
*TAF01845X16	.18	4.65	.45	11.5	.07	1.90	.03	.70	-	-	-	-	-	-	.226	5.75	.250	6.35	.003	.08	16	406	64
*TAF4T1845X16	.18	4.65	.45	11.5	.07	1.90	.03	.70	-	-	-	-	-	-	.226	5.75	.250	6.35	.003	.08	16	406	64



MOUNTING OPTIONS
 ■ Slot
 *May vary depending on application
 X - Select material/finish (see page 27)

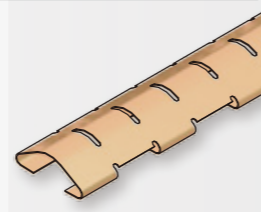
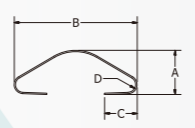

MOUNTING CONCEPTS

Alternate Finger Mounting Hole Recommendations

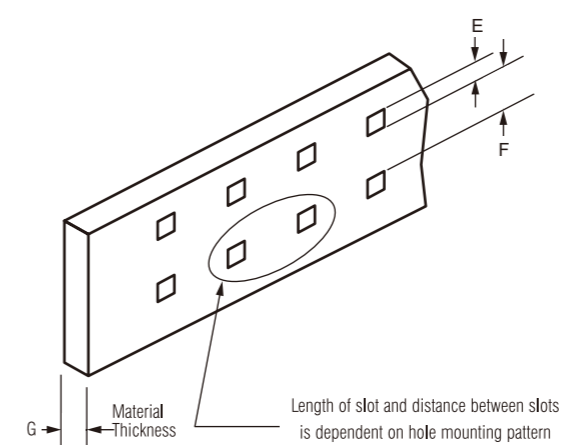

Variable Slot Mount Chart

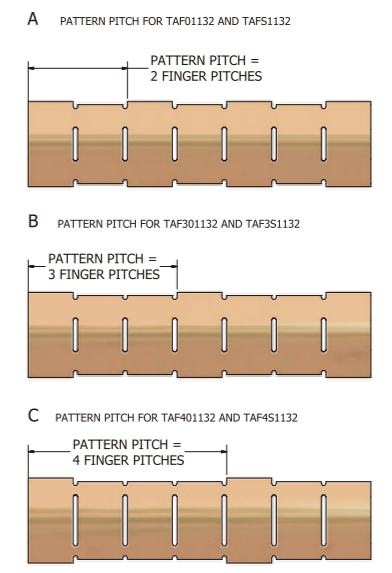

Slot Mount Series RH

Slot Mount Series RH														Black = inches		Red = mm							
SEM P/N	A		B		C		D		*N	*O	*P	FINGER	PITCH	MAT. THICK	LENGTH	FINGERS							
TRH01128X16	.11	2.79	.28	7.11	.08	2.03	.02	.51	.09	2.29	.22	5.59	.04	1.02	.169	4.29	.187	4.75	.003	.076	16	406	86
TRHS1128X16	.11	2.79	.28	7.11	.08	2.03	.02	.51	.09	2.29	.22	5.59	.04	1.02	.169	4.29	.187	4.75	.002	.054	16	406	86
TRH01132X16	.11	2.79	.32	8.13	.09	2.29	.02	.51	.09	2.29	.26	6.60	.04	1.02	.169	4.29	.187	4.75	.003	.076	16	406	86
*TRHA1132X16	.11	2.79	.32	8.13	.085	2.16	.02	.51	-	-	-	-	-	-	.169	4.29	.187	4.75	.003	.08	16	408.04	86
*TRHB1132X16	.11	2.79	.32	8.13	.085	2.16	.02	.51	-	-	-	-	-	-	.169	4.29	.187	4.75	.002	.06	16	408.04	86
TRHS1132X16	.11	2.79	.32	8.13	.085	2.16	.02	.51	.09	2.29	.26	6.60	.04	1.02	.169	4.29	.187	4.75	.002	.06	16	406	86
TRH01330X16	.13	3.30	.30	7.62	.09	2.29	.03	.76	.09	2.29	.25	6.35	.05	1.27	.169	4.29	.187	4.75	.004	.102	16	406	86
TRH01337X16	.13	3.30	.37	9.40	.09	2.29	.02	.51	.09	2.29	.31	7.87	.04	1.02	.225	5.72	.250	6.35	.003	.076	16	406	64
*TRHA1337X16	.13	3.3	.37	9.4	.085	2.16	.02	.51	-	-	-	-	-	-	.225	5.72	.250	6.35	.003	.08	16	405.77	64
TRHS1337X16	.13	3.30	.37	9.40	.09	2.29	.02	.51	.09	2.29	.31	7.87	.04	1.02	.225	5.72	.250	6.35	.002	.054	16	406	64
TRH02260X16	.22	5.59	.60	15.24	.14	3.56	.04	1.02	.14	3.56	.52	13.21	.06	1.52	.250	6.23	.282	7.16	.005	.127	16	406	57
TRHS2260X16	.22	5.59	.60	15.24	.14	3.56	.04	1.02	.14	3.56	.52	13.21	.06	1.52	.250	6.35	.282	7.16	.003	.076	16	406	57
*TRH01543X16	.15	3.88	.43	11	.11	2.7	.02	.57	-	-	-	-	-	-	.209	5.30	.236	6	.003	.08	16	407.3	68



MOUNTING OPTIONS
 ■ Slot
 May vary depending on application
 X - Select material/finish (see page 27)

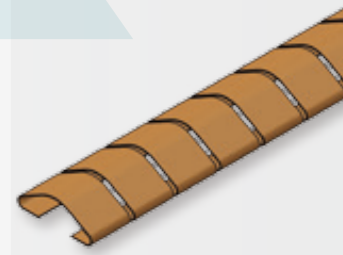
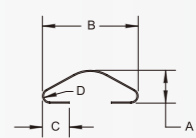

RH Mounting Hole Pattern

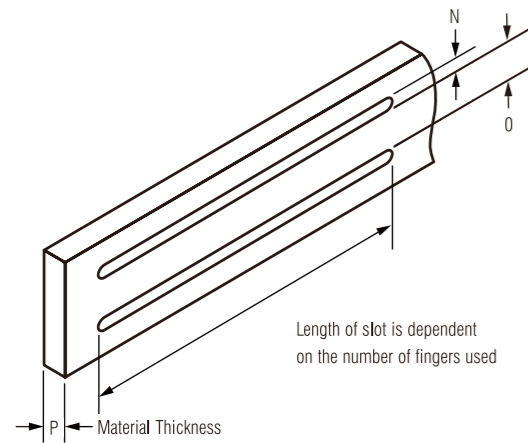

Slot Mount Series

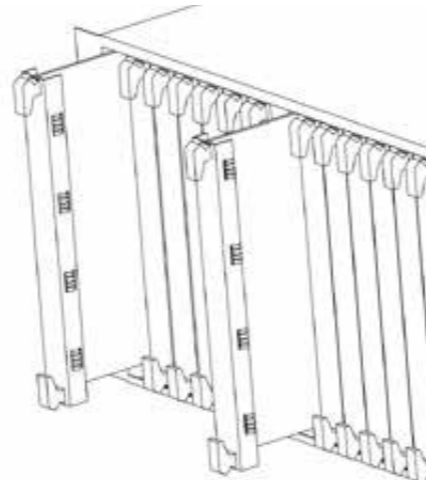

MOUNTING CONCEPTS

Folded Series GASKETS

SEM's Folded Gasket series are industry standard, general-purpose gaskets that allow a large range of deflection and compression forces. These gaskets are available with or without tape for alternate attachment methods. Also available in a snag-free version where, under compression, the leading edge of the gasket slides into an extended and folded base which prevents possible damage to the gasket.

Folded Series FS																	Black = inches Red = mm Comp = Compressed								
SEM P/N	A	B	C	FINGER	PITCH	MAT. THICK	COMP LENGTH	COMP HEIGHT	LENGTH	FINGERS	TAPE														
TFS01128X16	.11	2.79	.28	7.11	.24	6.10	.170	4.32	.188	4.78	.003	.076	.37	9.40	.07	1.78	16	406	85	.145					
TFS01128X300	.11	2.79	.28	7.11	.24	6.10	.170	4.32	.188	4.78	.003	.076	.37	9.40	.07	1.78	300	7620	1596	.145					
TFSS1128X16	.11	2.79	.28	7.11	.24	6.10	.170	4.32	.188	4.78	.002	.051	.37	9.40	.07	1.78	16	406	85	.145					
TFSS1128X300	.11	2.79	.28	7.11	.24	6.10	.170	4.32	.188	4.78	.002	.051	.37	9.40	.07	1.78	300	7620	1596	.145					
TFS01437X16	.14	3.56	.37	9.40	.32	8.13	.228	5.79	250	6.35	.003	.076	.50	12.70	.10	2.54	16	406	64	.200					
TFS01437X300	.14	3.56	.37	9.40	.32	8.13	.228	5.79	250	6.35	.003	.076	.50	12.70	.10	2.54	300	7620	1200	.200					
TFSS1437X16	.14	3.56	.37	9.40	.31	7.87	.228	5.79	250	6.35	.002	.051	.50	12.70	.10	2.54	16	406	64	.200					
TFSS1437X300	.14	3.56	.37	9.40	.31	7.87	.228	5.79	250	6.35	.002	.051	.50	12.70	.10	2.54	300	7620	1200	.200					
TFS02360X24	.23	5.84	.60	15.24	.50	12.70	.343	8.71	375	9.53	.004	.102	.77	19.56	.12	3.05	24	610	64	.250					
TFS02360X300	.23	5.84	.60	15.24	.50	12.70	.343	8.71	375	9.53	.004	.102	.77	19.56	.12	3.05	300	7620	800	.250					
TFS02578X24	.25	6.35	.78	19.81	.53	13.46	.335	8.51	375	9.53	.005	.127	.94	23.88	.15	3.81	24	610	64	.375					
TFS02578X300	.25	6.35	.78	19.81	.53	13.46	.340	8.64	375	9.53	.005	.127	.94	23.88	.15	3.81	300	7620	800	.375					
TFSS2578X24	.25	6.35	.78	19.81	.53	13.46	.335	8.51	375	9.53	.003	.076	.94	23.88	.15	3.81	24	610	64	.375					
TFSS2578X300	.25	6.35	.78	19.81	.53	13.46	.335	8.51	375	9.53	.003	.076	.94	23.88	.15	3.81	300	7620	800	.375					
TFS041113X12	.41	10.41	1.13	28.70	.80	20.32	.460	11.68	500	12.70	.007	.178	1.94	49.28	.23	5.84	12	305	24	.375					

Slot Mount Series (AT)

Slot Mount Series (AT)																	Black = inches Red = mm								
SEM P/N	A	B	C	D	E	FINGER	PITCH	MAT. THICK	LENGTH	FINGERS															
*TAT21132X16	.11	2.79	.32	8.13	.09	2.16	.11	2.79	.02	.51	.17	4.29	.19	4.75	.002	.05	16	408.04	86						



MOUNTING OPTIONS

X - Select material/finish (see page 27)

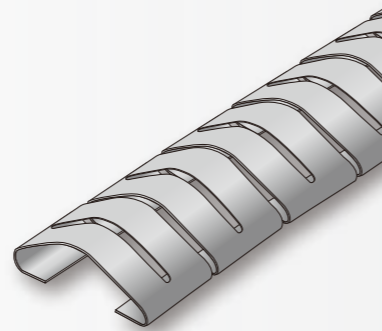
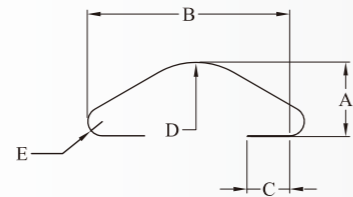

MOUNTING OPTIONS

- Tape
- Solder
- Rivet

The SEM FS gaskets are industry standard, general-purpose gaskets that allow a large range of deflection and compression forces. These gaskets are available without tape for alternate attachment methods. Consult factory for information.

X - Select material/finish (see page 27)

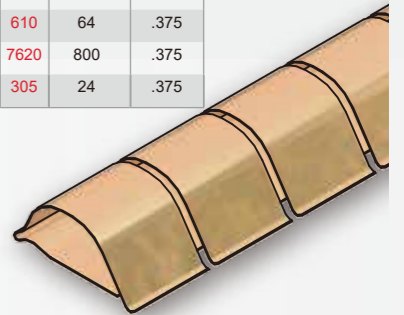
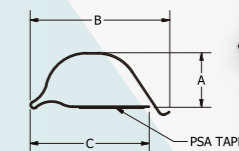

Folded Series FSH

Folded Series FSH																	Black = inches Red = mm							
SEM P/N	A	B	C	D	FINGER	PITCH	MAT. THICK	LENGTH	FINGERS															
*TFSH1128X16	.11	2.80	.28	7.10	.23	5.80	.059	1.50	.170	4.32	.189	4.78	.003	.08	16	406.30	85							
*TFSH1437X16	.14	3.60	.37	9.40	.31	7.90	.063	1.60	.228	5.79	.250	6.35	.003	.08	16	406.40	64							
*TFSH2360X16	.23	5.80	.60	15.20	.50	12.70	.079	2.00	.343	8.72	.375	9.53	.004	.10	16	406.40	43							
*TFSA2578X16	.25	6.40	.78	19.80	.53	13.50	.142	3.60	.335	8.51	.375	9.53	.004	.10	16	409.79	43							
*TFSB2578X16	.25	6.40	.78	19.80	.53	13.50	.142	3.60	.335	8.51	.375	9.53	.008	.20	16	409.79	43							
*TFSC2578X16	.25	6.40	.78	19.80	.94	24.00	.142	3.60	.335	8.51	.375	9.53	.004	.10	16	409.79	43							
*TFSH4111X16	.41	10.40	1.13	28.70	.78	19.80	.142	3.60	.460	11.68	.500	12.70	.007	.18	16	406.40	32							



MOUNTING OPTIONS

X - Select material/finish (see page 27)

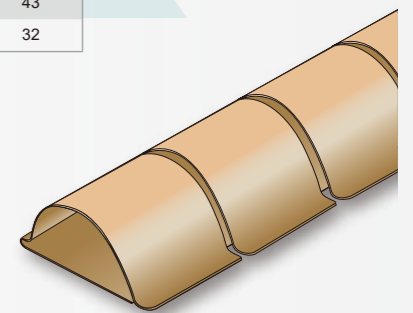
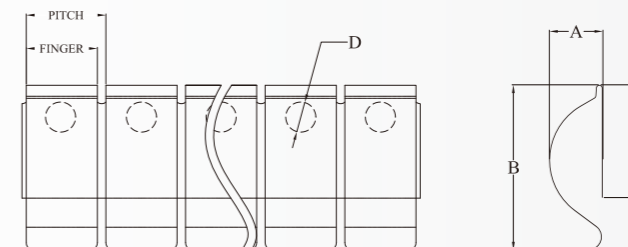

Folded Series FSC

Black = inches Red = mm

SEM P/N	A	B	FINGER	PITCH	MAT. THICK	COMP HEIGHT	LENGTH	FINGERS	TAPE							
*TFST0825X16	.08	2.00	0.25	6.40	.170	4.32	.188	4.78	.003	0.08	-	-	16	406.3	85	.157
TFSC0825X16	.08	2.03	.25	6.35	.170	4.32	.188	4.78	.003	.076	.048	1.22	16	406	85	.145
TFSC1451X16	.14	3.56	.51	12.95	.228	5.79	.250	6.35	.003	.076	.100	2.54	16	406	64	.375
TFSZ1451X16	.14	3.56	.51	12.95	.228	5.79	.250	6.35	.002	.051	.100	2.54	16	406	64	.375
TFSC2376X24	.23	5.84	.76	19.30	.343	8.64	.375	9.53	.004	.102	.115	2.92	24	610	64	.375



MOUNTING OPTIONS

- Tape
- Solder
- Rivet

The FSC was created to provide snag free gaskets with FS gasket features. The base of the gasket is extended from the mounting area and then folded up, over, down, and then comes to rest over the leading edge of the formed spring. Under compression, the leading edge of the gasket slides under and is "captured." This "no snag" feature is also used to prevent possible gasket damage.

X - Select material/finish (see page 27)

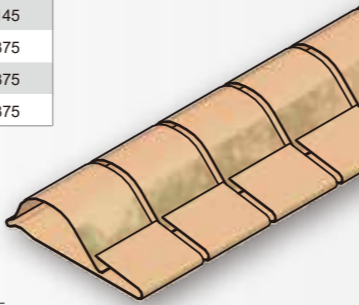
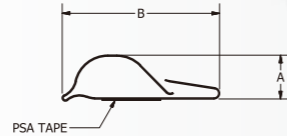

Folded Series FSV

Black = inches Red = mm Comp = Compressed

SEM P/N	A	B	C	D	E	FINGER	PITCH	MAT. THICK	COMP WIDTH	COMP HEIGHT	LENGTH	FINGERS											
TFSV1128X16	.11	2.79	.28	7.11	.24	6.10	.06	1.52	.188	4.78	.170	4.32	.188	4.78	.003	.076	.37	9.40	.07	1.78	16	406	85
*TFS01128X16	.11	2.8	.28	7.1	.22	5.7	.06	1.5	.189	4.78	.166	4.22	.189	4.78	.003	.08	-	-	-	-	16	406.3	85
TFS21128X16	.11	2.79	.28	7.11	.24	6.10	.06	1.52	.188	4.78	.170	4.32	.188	4.78	.002	.051	.37	9.40	.07	1.78	16	406	85
*TFSV1436X16	.14	3.6	.37	9.4	.32	8.13	.12	3	.250	6.35	.228	5.79	.250	6.35	.003	.08	-	-	-	-	16	406.4	64
TFSV1437X16	.14	3.66	.37	9.40	.32	8.13	.06	1.52	.250	6.35	.228	5.79	.250	6.35	.003	.076	.50	12.70	.10	2.54	16	406	64
TFS21437X16	.14	3.66	.37	9.40	.32	8.13	.06	1.52	.250	6.35	.228	5.79	.250	6.35	.002	.051	.50	12.70	.10	2.54	16	406	64
TFSV2360X24	.23	5.84	.60	15.24	.50	12.70	.08	2.03	.375	9.53	.343	8.71	.375	9.50	.004	.102	.77	19.56	.12	3.05	24	610	64
TFSV2578X24	.25	6.35	.78	19.81	.50	12.70	.14	3.56	.375	9.53	.335	8.51	.375	9.50	.005	.127	.94	23.88	.15	3.81	24	610	64
TFS22578X24	.25	6.35	.78	19.81	.50	12.70	.14	3.56	.375	9.53	.335	8.51	.375	9.50	.003	.076	.94	23.88	.15	3.81	24	610	64
*TFSV2674X16	.26	6.7	.74	18.7	.34	8.7	.14	3.6	.375	9.53	.335	8.51	.375	9.53	.005	.127	-	-	-	-	16	409.79	43
TFSV41113X12	.41	10.41	1.13	28.70	.80	20.32	.14	3.56	.500	12.70	.460	11.68	.500	12.70	.007	.178	1.94	49.28	.23	5.84	12	305	24
*TFSV42113X16	.42	10.7	1.13	28.7	.75	19.05	.14	3.6	.500	12.70	.460	11.68	.500	12.70	.007	.18	-	-	-	-	16	406.4	32



MOUNTING OPTIONS

- Tape
- Rivet
- Solder

The FSV is an FS gasket that has the base bent at a right angle to the curve of the spring form, with all the other features of the FS gasket maintained. Tape optional - please consult factory.

X - Select material/finish (see page 27)

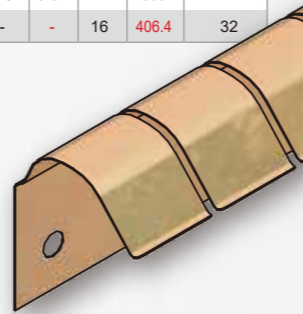
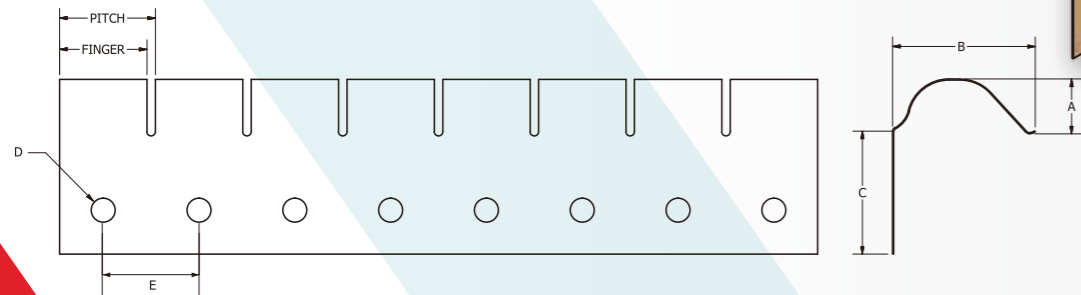

Folded Series FSD

Black = inches Red = mm Comp = Compressed

SEM P/N	A	B	C	D	E	FINGER	PITCH	MAT. THICK	COMP WIDTH	COMP HEIGHT	LENGTH	FINGERS											
TFSD2599X24	.25	6.35	1.09	27.69	.16	4.06	.14	3.56	.38	9.65	.335	8.51	.375	9.53	.005	.127	1.27	32.26	.15	3.81	24	610	64
TFSD2599X300	.25	6.35	1.09	27.69	.16	4.06	.14	3.56	.38	9.65	.335	8.51	.375	9.53	.005	.127	1.27	32.26	.15	3.81	300	7620	800
TFSS2599X24	.25	6.35	1.09	27.69	.16	4.06	.14	3.56	.38	9.65	.335	8.51	.375	9.53	.003	.076	1.27	32.26	.15	3.81	24	610	64
TFSS2599X300	.25	6.35	1.09	27.69	.16	4.06	.14	3.56	.38	9.65	.335	8.51	.375	9.53	.003	.076	1.27	32.26	.15	3.81	300	7620	800
TFSD41163X24	.41	10.41	1.63	41.40	.19	4.83	.14	3.56	.50	12.70	.460	11.68	.500	12.70	.007	.178	1.90	48.26	.23	5.84	24	610	48
TFSD41163X300	.41	10.41	1.63	41.40	.19	4.83	.14	3.56	.50	12.70	.460	11.68	.500	12.70	.007	.178	1.90	48.26	.23	5.84	300	7620	600
*TFSD25110X16	.25	6.40	1.1	27.70	.16	4.1	.14	3.6	.38	9.53	.335	8.51	.375	9.53	.003	.08	-	-	-	-	16	409.79	43
*TFSD41163X16	.41	10.40	1.63	41.40	.19	4.8	.14	3.6	.50	12.70	.460	11.68	.500	12.70	.007	.18	-	-	-	-	16	406.4	32



MOUNTING OPTIONS

- Tape
- Rivet
- Solder

The FSD is an FS gasket with its base lying on the same plane as the curve in the spring form, with the mounting area shortened. This mounting is often modified for custom applications.

X - Select material/finish (see page 27)

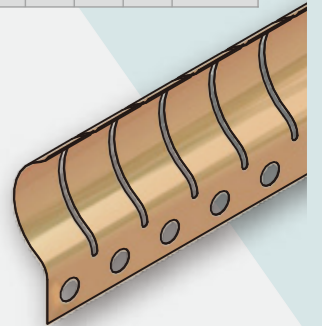
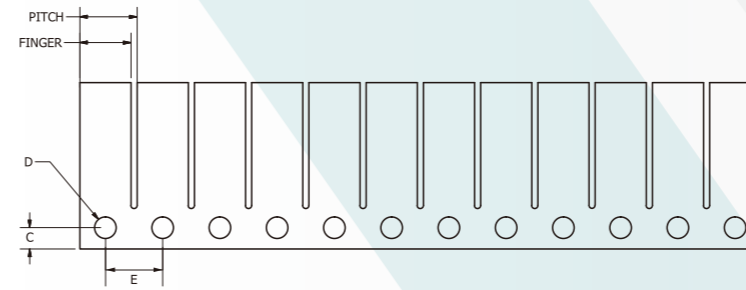

Twist Series GASKETS

The Twist series gaskets are designed for demanding compression applications. This series can compress to material thickness and provide excellent shielding performance. Profiles include standard flat, right angle, double twist, and clip-on.

Twist Series T

Black = inches Red = mm

SEM P/N	A	B	C	FINGER	PITCH	MAT. THICK	LENGTH	FINGERS	TAPE							
TT000320X24	.03	.76	.20	5.08	.11	2.79	.08	2.03	.095	2.41	.003	.076	24	610	253	.100
TT000320X300	.03	.76	.20	5.08	.11	2.79	.08	2.03	.095	2.41	.003	.076	300	7620	3158	.100
*TT000323X24	.03	.8	.23	5.9	.14	3.6	.08	2.03	.095	2.41	.003	.08	24	609.73	253	-
TT000323X300	.03	.76	.23	5.84	.14	3.56	.08	2.03	.095	2.41	.003	.076	300	7620	3158	.100
TT00S323X24	.03	.76	.23	5.84	.14	3.56	.08	2.03	.095	2.41	.002	.051	24	610	253	.100
TT00S323X300	.03	.76	.23	5.84	.14	3.56	.08	2.03	.095	2.41	.002	.051	300	7620	3158	.100
*TT000630X24	.07	1.8	.30	7.62	.15	3.81	.15	3.81	.165	4.19	.003	.08	24	611.74	146	-
TT000630X300	.07	1.78	.30	7.62	.15	3.81	.15	3.81	.165	4.19	.003	.076	300	7620	1818	.100
TT00S630X24	.07	1.78	.30	7.62	.15	3.81	.15	3.81	.165	4.19	.002	.051	24	610	146	.145
TT00S630X300	.07	1.78	.30	7.62	.15	3.81	.15	3.81	.165	4.19	.002	.051	300	7620	1818	.145
*TT000634X24	.07	1.8	.34	8.64	.18	4.63	.15	3.81	.165	4.19	.003	.08	24	611.74	146	-
TT000634X300	.07	1.78	.34	8.64	.18	4.57	.15	3.81	.165	4.19	.003	.076	300	7620	1818	.145
TT00S634X24	.07	1.78	.34	8.64	.18	4.57	.15	3.81	.165	4.19	.002	.051	24	610	146	.145
TT00S634X300	.07	1.78	.34	8.64	.18	4.57	.15	3.81	.165	4.19	.002	.051	300	7620	1818	.145

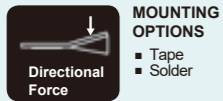

MOUNTING OPTIONS X - Select material/finish (see page 27)

- Tape
- Solder

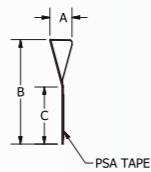

Twist Series TV

Black = inches Red = mm

SEM P/N	A	B	C	FINGER	PITCH	MAT. THICK	LENGTH	FINGERS	TAPE							
TTV00323X24	.03	.76	.08	2.03	.16	4.06	.08	2.03	.095	2.41	.003	.076	24	610	253	.100
*TTV00320X24	.03	.80	.07	2	.15	3.8	.08	2.03	.095	2.41	.003	.08	24	609.73	253	-
TTV00323X30	.03	.76	.08	2.03	.16	4.06	.08	2.03	.095	2.41	.003	.076	300	7620	3158	.100
TTV0323X24	.03	.76	.08	2.03	.30	7.62	.08	2.03	.095	2.41	.003	.076	24	610	253	.250
TTV0S323X24	.03	.76	.08	2.03	.16	4.06	.08	2.03	.095	2.41	.002	.051	24	610	253	.100
TTV30S323X300	.03	.76	.08	2.03	.30	7.62	.08	2.03	.095	2.41	.002	.051	300	7620	3158	.250
TTV00634X24	.07	1.78	.14	3.56	.20	5.08	.15	3.81	.165	4.19	.003	.076	24	610	146	.145
TTV00634X300	.07	1.78	.14	3.56	.20	5.08	.15	3.81	.165	4.19	.003	.076	300	7620	1818	.145
TTV0S634X24	.07	1.78	.14	3.56	.20	5.08	.15	3.81	.165	4.19	.002	.051	24	610	146	.145
*TTV00640X24	.07	1.8	.14	4	.18	4.63	.15	3.81	.165	4.19	.003	.08	24	611.74	146	-
TTV0S634X300	.07	1.78	.14	3.56	.20	5.08	.15	3.81	.165	4.19	.002	.051	300	7620	1818	.145



MOUNTING OPTIONS X - Select material/finish (see page 27)

- Tape
- Solder

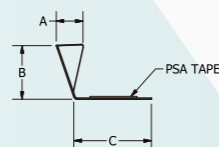

Twist Series T2

Black = inches Red = mm

SEM P/N	A	B	C	FINGER	PITCH	MAT. THICK	LENGTH	FINGERS	TAPE							
TT200650X24	.07	1.78	.50	12.70	.18	4.57	.15	3.81	.165	4.19	.003	.076	24	610	146	.145
TT200650X300	.07	1.78	.50	12.70	.18	4.57	.15	3.81	.165	4.19	.003	.076	300	7620	1818	.145
TT20S650X24	.07	1.78	.50	12.70	.18	4.57	.15	3.81	.165	4.19	.002	.051	24	610	146	.145
TT20S650X300	.07	1.78	.50	12.70	.18	4.57	.15	3.81	.165	4.19	.002	.051	300	7620	1818	.145



MOUNTING OPTIONS X - Select material/finish (see page 27)

- Tape

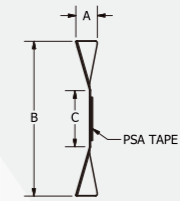

Twist Series UT

Black = inches Red = mm

SEM P/N	A	B	FINGER	PITCH	MAT. THICK	LENGTH	FINGERS	CLIP ID	LANCE	LANCE PITCH							
TUT40323X16	.03	.76	.15	3.81	.08	2.03	.095	2.41	.003	.076	16	406	168	.04	1.02	n/a	n/a
TUT70323X16	.03	.76	.15	3.81	.08	2.03	.095	2.41	.003	.076	16	406	168	.07	1.78	n/a	n/a
TUT7D323X16	.03	.76	.15	3.81	.08	2.03	.095	2.41	.003	.076	16	406	168	.07	1.78	D	1"
TUT40634X16	.07	1.78	.22	5.59	.15	3.81	.165	4.19	.003	.076	16	406	97	.04	1.02	n/a	n/a
TUT70634X16	.07	1.78	.22	5.59	.15	3.81	.165	4.19	.003	.076	16	406	97	.07	1.78	n/a	n/a
TUT7D634X16	.07	1.78	.22	5.59	.15	3.81	.165	4.19	.003	.076	16	406	97	.07	1.78	D	1"



MOUNTING OPTIONS X - Select material/finish (see page 27)

- Clip



Twist Series UT3

Black = inches Red = mm

SEM P/N	A	B	C	FINGER	PITCH	MAT. THICK	LENGTH	FINGERS	CLIP ID	LANCE	LANCE PITCH								
TUT305634X16	.07	1.78	.38	9.65	.22	5.59	.15	3.81	.165	4.19	.003	.076	16	406	97	.05	1.27	n/a	n/a
TUT3D5634X16	.07	1.78	.38	9.65	.22	5.59	.15	3.81	.165	4.19	.003	.076	16	406	97	.05	1.27	D	1"
TUT307634X16	.07	1.78	.38	9.65	.22	5.59	.15	3.81	.165	4.19	.003	.076	16	406	97	.07	1.78	n/a	n/a
TUT3D7634X16	.07	1.78	.38	9.65	.22	5.59	.15	3.81	.165	4.19	.003	.076	16	406	97	.07	1.78	D	1"



MOUNTING OPTIONS X - Select material/finish (see page 27)

- Clip

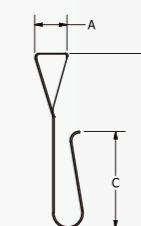

Clip-On Series GASKETS

The Clip-On Gaskets are used in enclosures, shielded cabinets, and on circuit cards as ESD contacts and EMI gaskets. For edge mount applications, close attention must be given to clip size, lance requirements, deflection parameters and finger configuration. SEM provides application assistance in the development of specifications.

Clip-On Series C														Black = inches		Red = mm		Comp = Compressed				
SEM P/N	A	B	C	FINGER	PITCH	MATERIAL THICK	COMP WIDTH	COMP HEIGHT	LANCE START	LANCE PITCH	FINGERS	LANCE										
TCD01030X16	.10	2.54	.30	7.62	.07	1.78	.135	3.43	.182	4.62	.005	.127	.33	8.38	.05	1.27	.341	8.66	.728	18.49	88	D
TCT01030X16	.10	2.54	.30	7.62	.07	1.78	.135	3.43	.182	4.62	.005	.127	.33	8.38	.05	1.27	.341	8.66	.728	18.49	88	T
TCD01145X16	.11	2.79	.45	11.43	.07	1.78	.147	3.73	.193	4.90	.005	.127	.47	11.94	.06	1.52	.267	6.78	.748	19.00	84	D
TCT01145X16	.11	2.79	.45	11.43	.07	1.78	.147	3.73	.193	4.90	.005	.127	.47	11.94	.06	1.52	.651	16.54	1.352	34.34	84	T

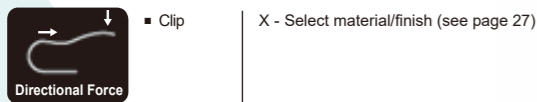

TCD01030

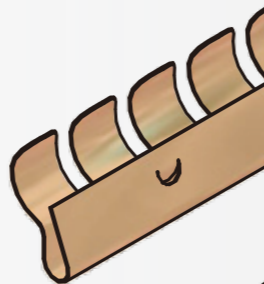
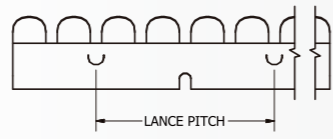
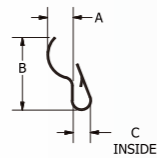
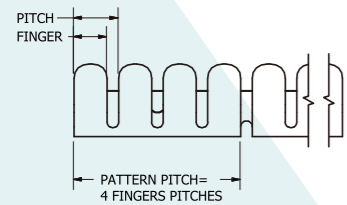

TCT01030

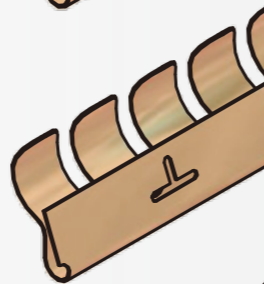
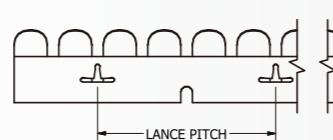
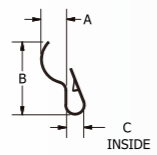
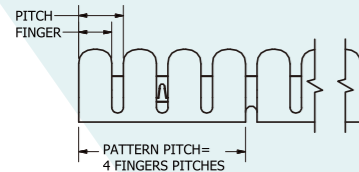

TCD01145

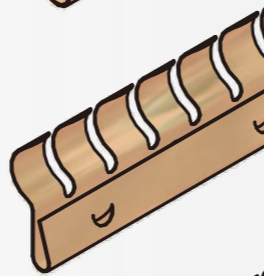
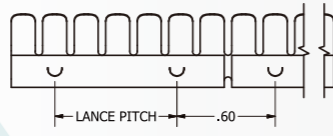
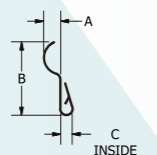
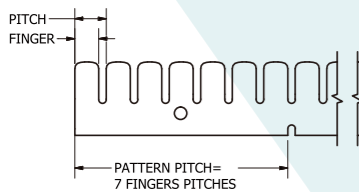

TCT01145

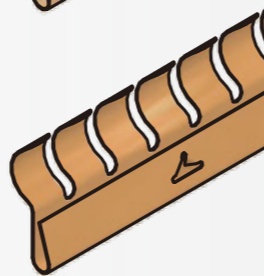
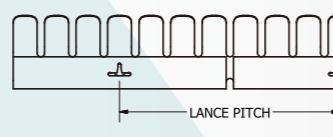
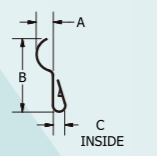
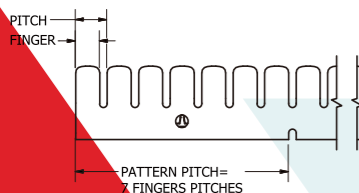

Mini-Clip Series C

SEM P/N	A	B	C	FINGER	PITCH	MATERIAL THICK	LANCE START	LANCE PITCH	LENGTH	FINGERS	CLIP ID	LANCE									
TCD40721X16	.07	1.78	.25	6.35	.03	.76	.170	4.32	.200	5.08	.003	.076	.49	12.45	1.00	25.40	16	406	80	.045	D

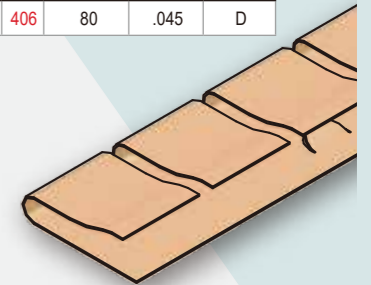
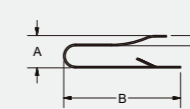
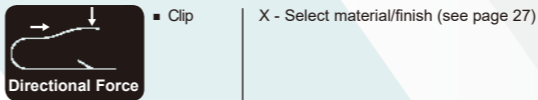

Clip-On Series C

SEM P/N	A	B	C	FINGER	PITCH	MATERIAL THICK	COMP WIDTH	COMP HEIGHT	LANCE START	LANCE PITCH	FINGERS	LANCE										
TC041030X16	.10	2.54	.30	7.62	.045	1.14	.140	3.560	.187	4.750	.005	.127	.33	8.38	.05	1.27	-	-	-	-	86	n/a
TC051030X16	.10	2.54	.30	7.62	.050	1.27	.140	3.560	.187	4.750	.005	.127	.33	8.38	.05	1.27	-	-	-	-	86	n/a
TC061030X16	.10	2.54	.30	7.62	.065	1.65	.140	3.560	.187	4.750	.005	.127	.33	8.38	.05	1.27	-	-	-	-	86	n/a
TC071030X16	.10	2.54	.30	7.62	.070	1.78	.140	3.560	.187	4.750	.005	.127	.33	8.38	.05	1.27	-	-	-	-	86	n/a
TCD41030X16	.10	2.54	.30	7.62	.045	1.14	.140	3.560	.187	4.75	.005	.127	.33	8.38	.05	1.27	.5	12.7	1	25.4	86	D
TCD51030X16	.10	2.54	.30	7.62	.050	1.27	.140	3.560	.187	4.750	.005	.127	.33	8.38	.05	1.27	.5	12.7	1	25.4	86	D
TCD61030X16	.10	2.54	.30	7.62	.065	1.65	.140	3.560	.187	4.750	.005	.127	.33	8.38	.05	1.27	.5	12.7	1	25.4	86	D
TCD71030X16	.10	2.54	.30	7.62	.070	1.78	.140	3.560	.187	4.750	.005	.127	.33	8.38	.05	1.27	.5	12.7	1	25.4	86	D
TC041145X16	.11	2.79	.45	11.43	.045	1.14	.140	3.560	.187	4.750	.005	.127	.47	11.94	.06	1.52	-	-	-	-	86	n/a
TC051145X16	.11	2.79	.45	11.43	.050	1.27	.140	3.560	.187	4.750	.005	.127	.47	11.94	.06	1.52	-	-	-	-	86	n/a
TC061145X16	.11	2.79	.45	11.43	.065	1.65	.140	3.560	.187	4.750	.005	.127	.47	11.94	.06	1.52	-	-	-	-	86	n/a
TC071145X16	.11	2.79	.45	11.43	.070	1.78	.140	3.560	.187	4.750	.005	.127	.47	11.94	.06	1.52	-	-	-	-	86	n/a
TCD41145X16	.11	2.79	.45	11.43	.045	1.14	.140	3.560	.187	4.750	.005	.127	.47	11.94	.06	1.52	.5	12.7	1	25.4	86	D
TCD51145X16	.11	2.79	.45	11.43	.050	1.27	.140	3.560	.187	4.750	.005	.127	.47	11.94	.06	1.52	.5	12.7	1	25.4	86	D
TCD61145X16	.11	2.79	.45	11.43	.065	1.65	.140	3.560	.187	4.750	.005	.127	.47	11.94	.06	1.52	.5	12.7	1	25.4	86	D
TCD71145X16	.11	2.79	.45	11.43	.070	1.78	.140	3.560	.187	4.750	.005	.127	.47	11.94	.06	1.52	.5	12.7	1	25.4	86	D
TC072599X16	.25	6.35	1.09	27.69	.070	1.78	.340	8.640	.375	9.530	.005	.127	1.27	32.26	.08	2.03	-	-	-	-	43	n/a
TCD72599X16	.25	6.35	1.09	27.69	.070	1.78	.340	8.640	.375	9.530	.005	.127	1.27	32.26	.08	2.03	.5	12.7	1	25.4	43	D
TSC072599X16	.25	6.35	1.09	27.69	.070	1.78	.340	8.640	.375	9.530	.003	.076	1.27	32.26	.08	2.03	-	-	-	-	43	n/a
TSCD72599X16	.25	6.35	1.09	27.69	.070	1.78	.340	8.640	.375	9.530	.003	.076	1.27	32.26	.08	2.03	.5	12.7	1	25.4	43	D
TC122599X16	.25	6.35	1.09	27.69	.120	3.05	.340	8.640	.375	9.530	.005	.127	1.27	32.26	.08	2.03	-	-	-	-	43	n/a
TC132599X16	.25	6.35	1.09	27.69	.130	3.30	.340	8.640	.375	9.530	.005	.127	1.27	32.26	.08	2.03	-	-	-	-	43	n/a

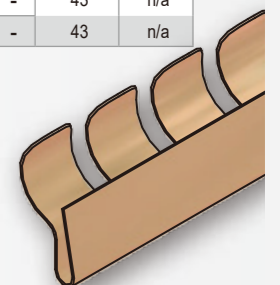
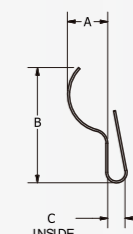
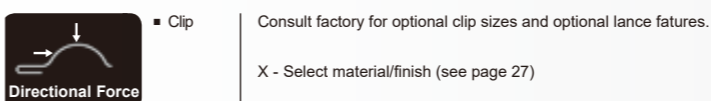

Clip-On & Grounding Series GASKETS

Clip-On Series CPS

Black = inches Red = mm

SEM P/N	A	B	C	FINGER	PITCH	MATERIAL THICK	LENGTH	FINGERS/STRIP	LANCE							
TCP02555X16	.25	6.35	.55	13.97	.04	1.02	.220	5.59	.250	6.35	.004	.102	16	406	64	D

X - Select material/finish (see page 27)

Perpendicular Shielding Gaskets

- Finger design allows for continuous contact across the length of the strip
- "D" lance provides superior retention of gasket to the mounting surface
- .80 D-clip is retained with .100 D-hole

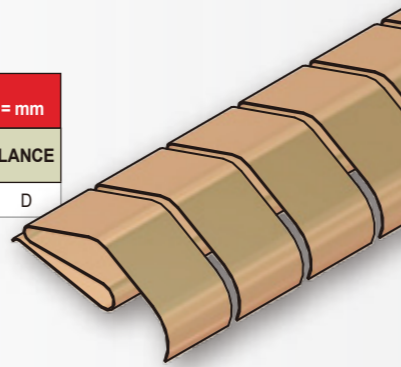
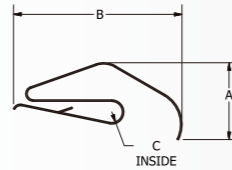

Clip-On Series CPG

Black = inches Red = mm

SEM P/N	A	B	C	FINGER	PITCH	MATERIAL THICK	LENGTH	FINGERS/STRIP	LANCE							
TCPG0631X12	.06	1.52	.31	7.87	.04	1.02	.500	12.70	.545	13.84	.004	.102	12	305	22	D
TCPG0631X16	.06	1.52	.31	7.87	.04	1.02	.500	12.70	.545	13.84	.004	.102	16	406	29	D

X - Select material/finish (see page 27)

Perpendicular Electrical Grounding Strips

- Finger extension provides grounding from card or PCB to a backplane housing surface
- Wide clip-on area with "D" lance offers reliable retention
- .0035 material offers significant resiliency

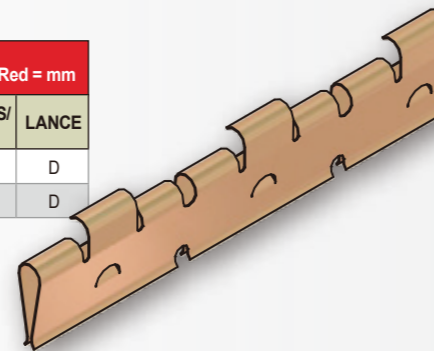
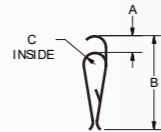

Grounding Series ML

Black = inches Red = mm

SEM P/N	A	B	C	FINGER	PITCH	MATERIAL THICK	FINGERS						
TML01481X16	.14	3.56	.28	7.11	.18	4.57	.080	2.03	.500	12.70	.005	.127	32
TML01481X24	.14	3.56	.28	7.11	.18	4.57	.080	2.03	.500	12.70	.005	.127	48

XX - Select material/finish (see page 27)

MOUNTING OPTIONS

- Tape

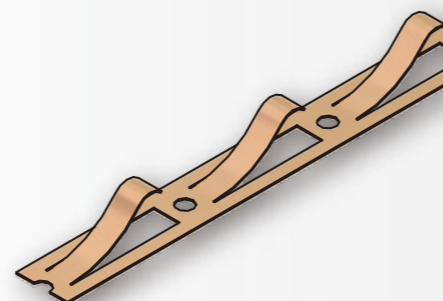
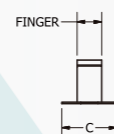
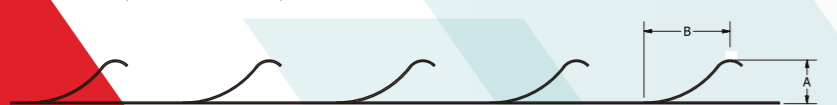
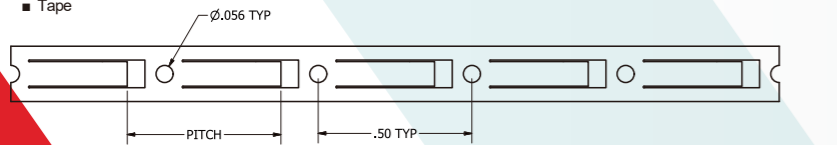

Clip-On Series

Black = inches Red = mm

SEM P/N	A	B	C	D	E	FINGER	PITCH	MAT. THICK	LENGTH	FINGERS									
*TCT22638X16	.26	6.7	.38	9.7	.026	0.65	.368	9.35	.265	6.72	.460	11.68	.50	12.7	.005	0.127	16	406.4	64

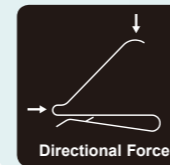

MOUNTING OPTIONS

X - Select material/finish (see page 27)

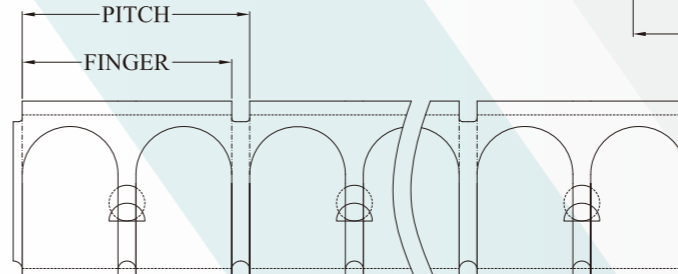
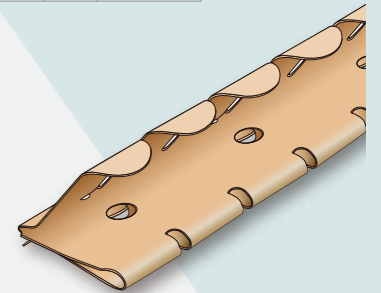
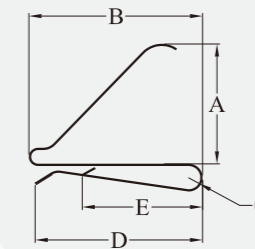

Clip-On Series

Black = inches Red = mm

SEM P/N	A	B	C	D	E	FINGER	PITCH	MAT. THICK	LENGTH	FINGERS									
*TCA02638X16	.26	6.70	.38	9.70	.026	0.65	.368	9.35	.265	6.72	.210	5.33	.25	6.35	.005	0.127	16	406.4	64
*TCB02638X16	.26	6.70	.38	9.70	.026	0.65	.368	9.35	.283	7.20	.210	5.33	.25	6.35	.005	0.127	16	406.4	64



MOUNTING OPTIONS

X - Select material/finish (see page 27)

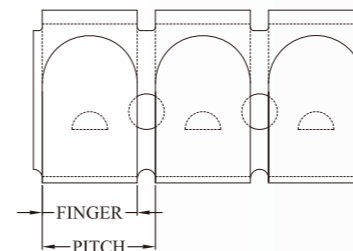
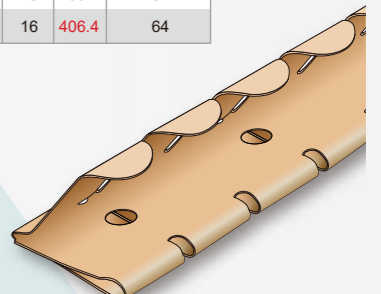
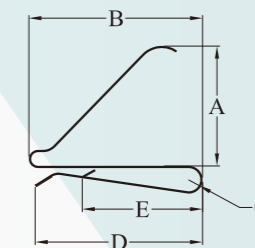

Clip-On Series

Black = inches Red = mm

SEM P/N	A	B	C	D	E	FINGER	PITCH	MAT. THICK	LENGTH	FINGERS									
*TCT02554X16	.25	6.35	.54	13.82	.031	0.8	.18	4.58	.260	6.5	.220	5.59	.25	6.35	.005	0.127	16	406.4	64

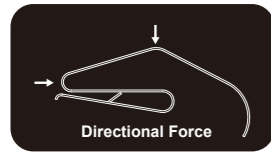

MOUNTING OPTIONS XX - Select material/finish (see page 27)

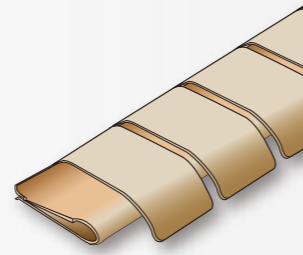
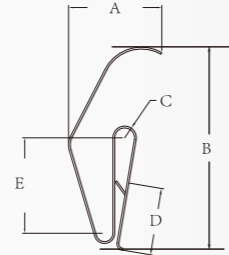
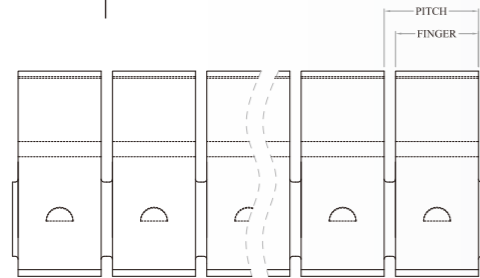

Clip-On Series

Black = inches Red = mm

SEM P/N	A	B	C	FINGER	PITCH	MAT. THICK	LENGTH	FINGERS							
*TCT01933X16	.19	4.85	.33	8.45	.03	0.8	.22	5.59	.25	6.35	.005	0.127	16	406.4	64

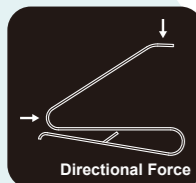

MOUNTING OPTIONS X - Select material/finish (see page 27)

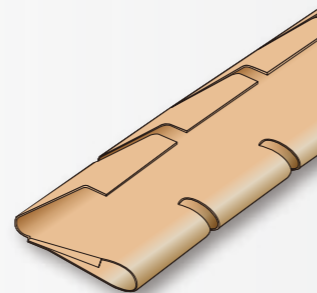
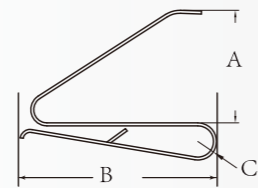
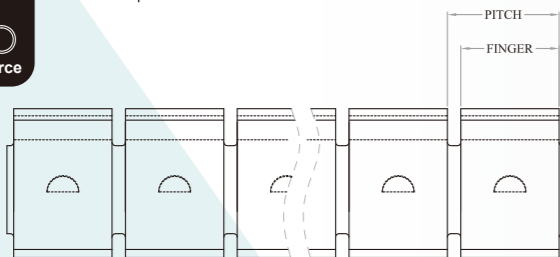

Clip-On Series

Black = inches Red = mm

SEM P/N	A	B	C	D	E	FINGER	PITCH	MAT. THICK	LENGTH	FINGERS									
*TCH0624107X16	.24	5.97	1.07	27.18	.06	1.65	-	.14	3.60	.34	8.51	.38	9.53	.005	0.12	16	409.79	43	
*TCH0824107X16	.24	5.97	1.07	27.18	.08	2.10	.31	7.90	.14	3.60	.34	8.51	.38	9.53	.004	0.10	16	409.79	43

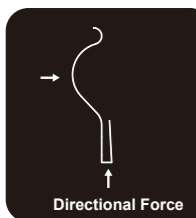

MOUNTING OPTIONS X - Select material/finish (see page 27)

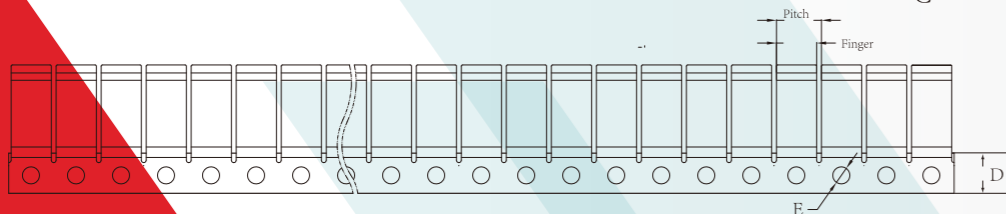
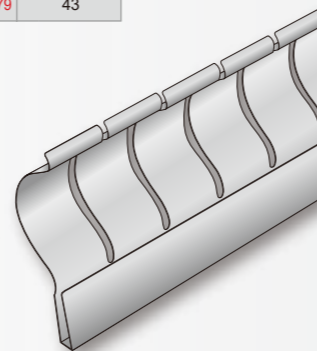
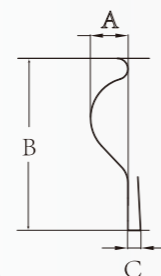

Contact Series GASKETS

Contact gaskets are primarily used for grounding and shielding in high frequency applications. These gaskets provide engineers and designers with flexibility to solve their shielding and grounding issues. They are available in a variety of different lengths, widths and profiles. Standard factory length for Contact Series strips is 16". Individual contacts available in tape & reel packaging. Adhesive tape is optional - please consult factory.

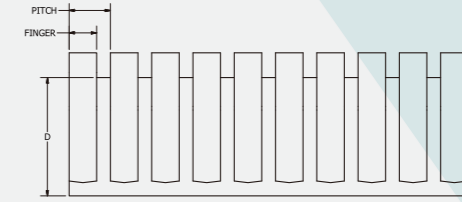

TUD00919

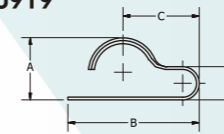

TUD01026

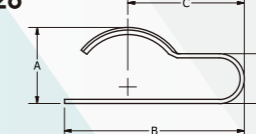

TUD01644

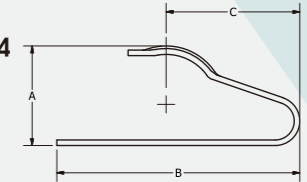

TUD00919 TUD01026 TUD01644 Contact Series

Black = inches Red = mm

SEM P/N	A	B	C	D	FINGER	PITCH	MAT. THICK	LENGTH	FINGERS/STRIP	TAPE								
TUD00919X16	.09	2.29	.19	4.83	.11	2.79	.13	3.30	.040	1.02	.060	1.52	.004	.102	16	406	266	NO
TUD01026X16	.11	2.79	.26	6.60	.17	4.32	.22	5.59	.050	1.27	.075	1.90	.006	.152	16	406	213	NO
TUD01644X16	.16	4.06	.44	11.18	.24	6.10	.33	8.38	.062	1.57	.093	2.36	.010	.254	16	406	172	NO

X - Select material/finish (see page 27)

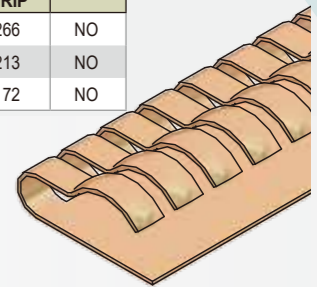

TD000434

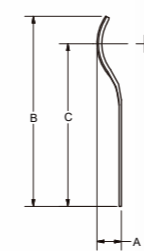

TD000438

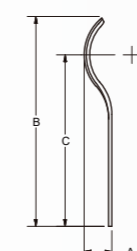

TD000453/
TT000453

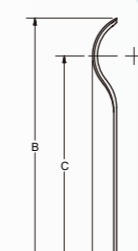

TD000978

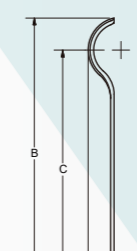

TDA00978

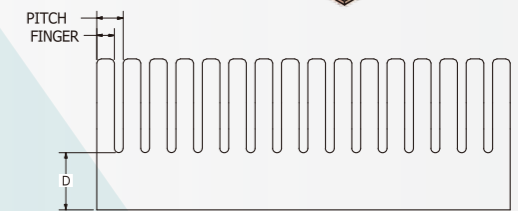
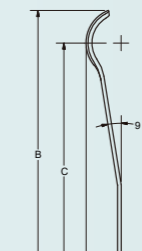

TD000434 TD000438 TD000453 TT000453 TD000978 TDA00978 Contact Series

Black = inches Red = mm

SEM P/N	A	B	C	D	FINGER	PITCH	MAT. THICK	LENGTH	FINGERS/STRIP	TAPE								
TD000434X16	.04	1.02	.34	8.63	.29	7.37	.13	3.30	.040	1.02	.060	1.52	.004	.101	16	406	266	NO
TD000438X16	.05	1.27	.38	9.65	.31	7.87	.062	1.575	.050	1.27	.075	1.90	.006	.152	16	406	213	NO
TD000453X16	.05	1.27	.53	13.46	.47	11.94	.22	5.59	.050	1.27	.075	1.90	.006	.152	16	406	213	NO
*TT000453X16	.05	1.3	.53	13.5	.47	11.9	.22	5.6	.050	1.27	.075	1.91	.006	.127	16	406.19	213	NO
TD000978X16	.05	1.27	.78	19.81	.66	16.76	.31	7.87	.062	1.57	.093	2.36	.010	.254	16	406	172	NO
TDA00978X16	.09	2.29	.78	19.81	.66	16.76	.31	7.87	.062	1.57	.093	2.36	.010	.254	16	406	172	NO

X - Select material/finish (see page 27)

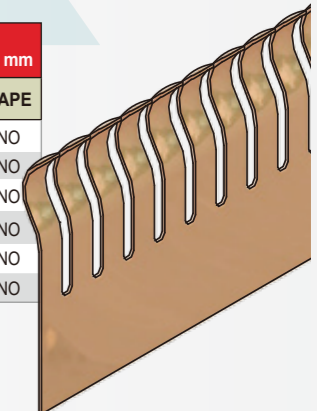

Contact Series GASKETS

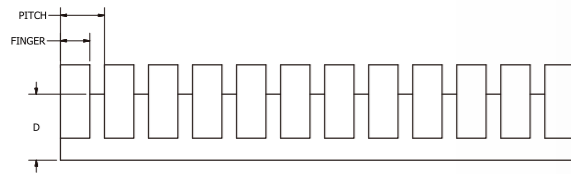

TU000713

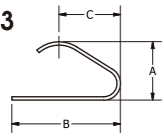

TU001328

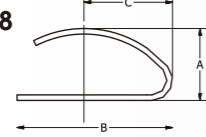

TU002849

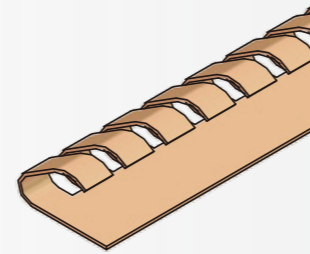
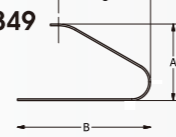

TU000713 TU001328 TU002849 Contact Series Black = inches Red = mm

SEM P/N	A	B	C	D	FINGER	PITCH	MAT. THICK	LENGTH	FINGERS/STRIP	TAPE								
TU000713X16	.07	1.78	.13	3.30	.07	1.78	.09	2.29	.040	1.02	.060	1.52	.004	.102	16	406	266	NO
TU001328X16	.13	3.30	.28	7.11	.16	4.06	.23	5.84	.095	2.41	.135	3.43	.010	.254	16	406	118	NO
TU002849X16	.28	7.11	.49	12.45	.34	8.64	.38	9.65	.125	3.17	.187	4.75	.006	.152	16	406	85	NO

X - Select material/finish (see page 27)

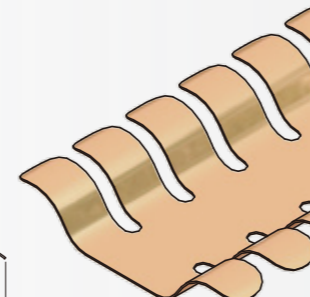
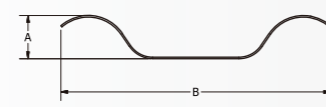
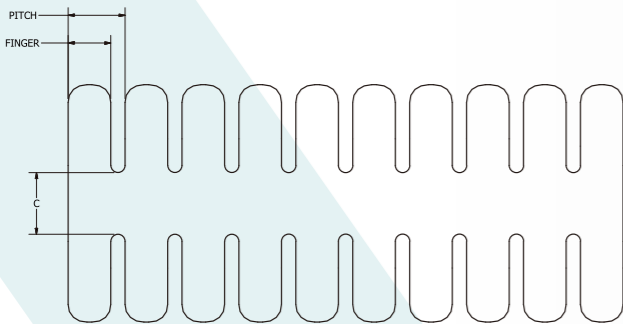

TR201178 Contact Series Black = inches Red = mm

SEM P/N	A	B	C	FINGER	PITCH	MAT. THICK	LENGTH	FINGERS/STRIP	TAPE							
TR201178X16	.13	3.30	.78	19.81	.20	5.08	.140	3.56	.187	4.750	.005	.127	16	406	86	NO

X - Select material/finish (see page 27)

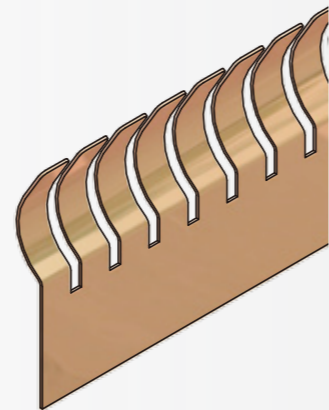
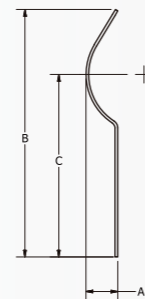
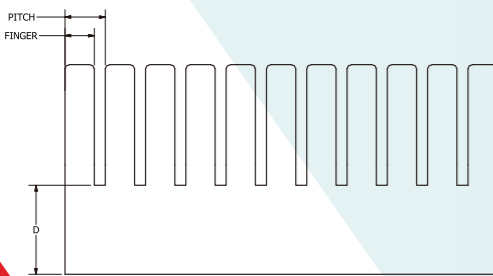

TS001190 Contact Series Black = inches Red = mm

SEM P/N	A	B	C	D	FINGER	PITCH	MAT. THICK	LENGTH	FINGERS/STRIP								
TS01190X16	.11	2.79	.90	22.86	.66	16.76	.38	9.65	.125	3.17	.172	4.37	.010	.254	16	406	93

X - Select material/finish (see page 27)

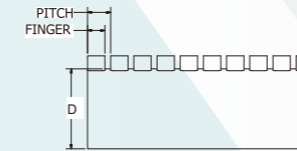

TRS01275 Contact Series Black = inches Red = mm

SEM P/N	A	B	C	D	FINGER	PITCH	MAT. THICK	LENGTH	FINGERS/STRIP	TAPE								
TRS01275X16	.12	3.05	.75	19.05	.12	3.05	.65	16.51	.140	3.56	.187	4.75	.005	.127	16	406	85	YES

X - Select material/finish (see page 27)

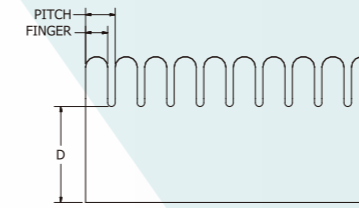
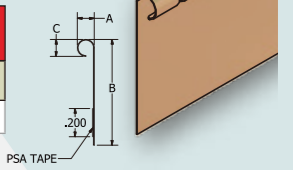

TRB00892 Contact Series Black = inches Red = mm

SEM P/N	A	B	C	D	FINGER	PITCH	MAT. THICK	LENGTH	FINGERS/STRIP	TAPE								
TRB00892X16	.09	2.29	.92	23.37	.30	7.62	.61	15.49	.140	3.56	.187	4.75	.005	.127	16	406	85	NO

X - Select material/finish (see page 27)

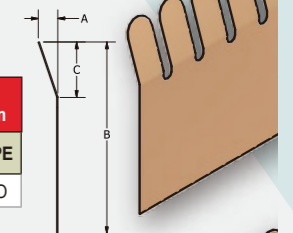

TRC00892 Contact Series Black = inches Red = mm

SEM P/N	A	B	C	D	FINGER	PITCH	MAT. THICK	LENGTH	FINGERS/STRIP	TAPE								
TRC00892X16	.09	2.29	.92	23.37	.30	7.62	.63	16.00	.140	3.56	.187	4.75	.005	.127	16	406	85	NO

X - Select material/finish (see page 27)

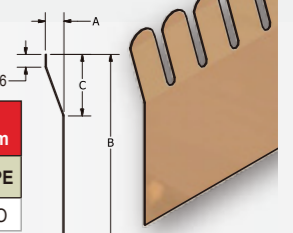

TRA01189 Contact Series Black = inches Red = mm

SEM P/N	A	B	C	D	FINGER	PITCH	MAT. THICK	LENGTH	FINGERS/STRIP	TAPE								
TRA01189X16	.13	3.30	.89	22.61	.81	20.57	.60	15.24	.140	3.56	.187	4.75	.005	.127	16	406	85	NO

X - Select material/finish (see page 27)

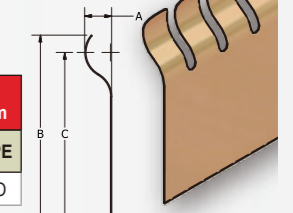

TRR02277 Contact Series Black = inches Red = mm

SEM P/N	A	B	C	D	FINGER	PITCH	MAT. THICK	LENGTH	FINGERS/STRIP	TAPE								
TRR02277X16	.23	5.84	.77	19.56	.64	16.26	.62	15.75	.140	3.56	.187	4.75	.005	.127	16	406	85	NO

X - Select material/finish (see page 27)

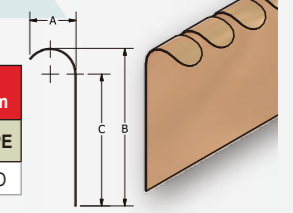

Pin D Connectors

TT9DXX 9 Pin Connector- .004" Thick

Part Number	Material	A	B
TT9D01	Stainless Steel	.44"	.22"
TT9D21	Beryllium Copper	.44"	.22"

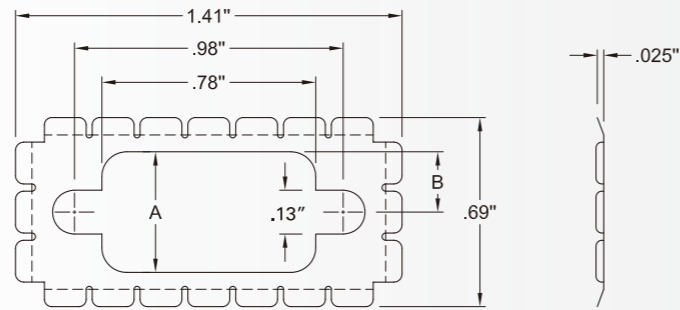

TT15DXX 15 Pin Connector- .004" Thick

Part Number	Material	A	B
TT15D01	Stainless Steel	.44"	.22"
TT15D21	Beryllium Copper	.44"	.22"

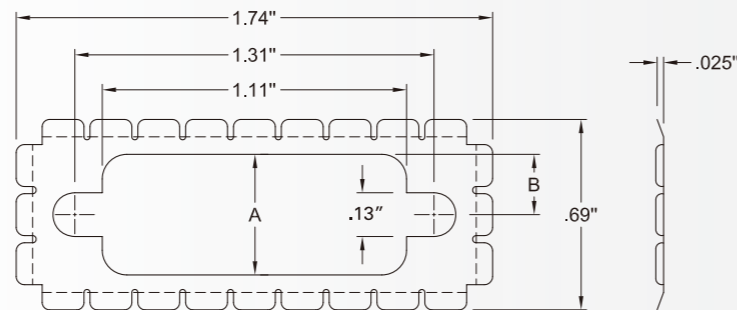

TT25DXX 25 Pin Connector- .004" Thick

Part Number	Material	A	B
TT25D01	Stainless Steel	.44"	.22"
TT25D21	Beryllium Copper	.44"	.22"

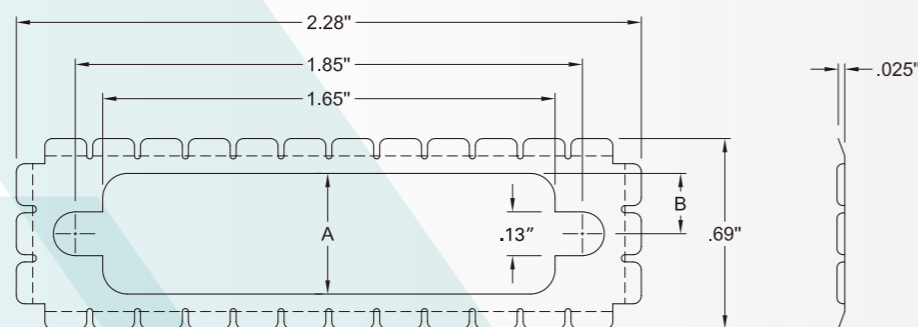

TT37DXX 37 Pin Connector- .004" Thick

Part Number	Material	A	B
TT37D01	Stainless Steel	.44"	.22"
TT37D21	Beryllium Copper	.44"	.22"

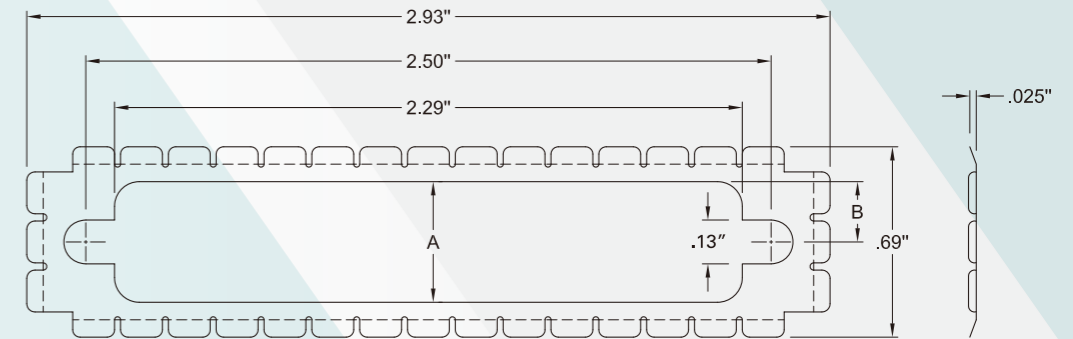

TT50DXX 50 Pin Connector- .004" Thick

Part Number	Material	A	B
TT50D01	Stainless Steel	.55"	.28"
TT50D21	Beryllium Copper	.55"	.28"

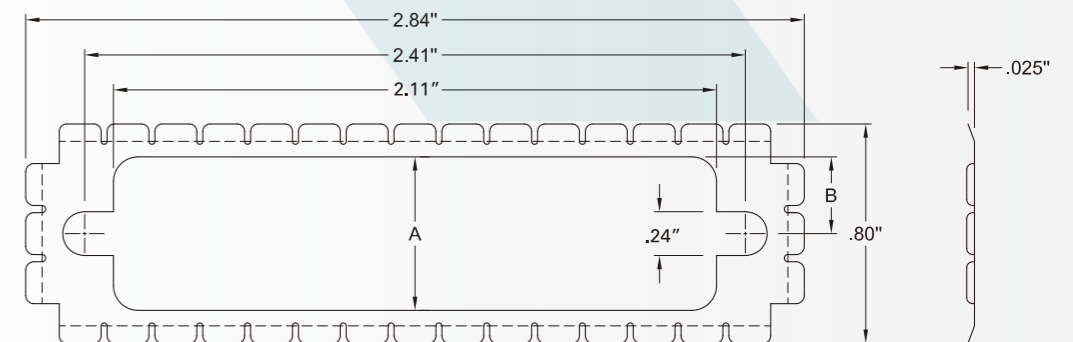

Pin D Connectors

SC3E00081 Connector- .004" Thick

Part Number	Material	A	B
SC3E00081	Beryllium Copper	.26"	.13"

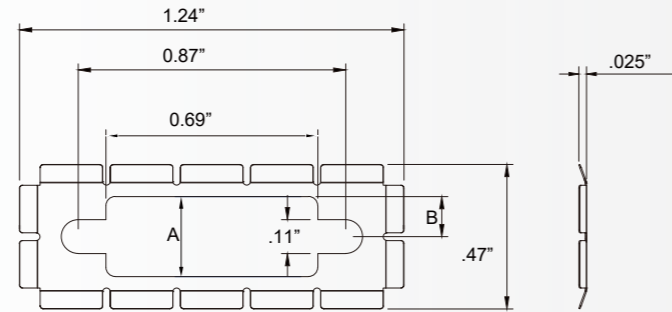

SC3E00083 Connector- .004" Thick

Part Number	Material	A	B
SC3E00083	Beryllium Copper	.30"	.15"

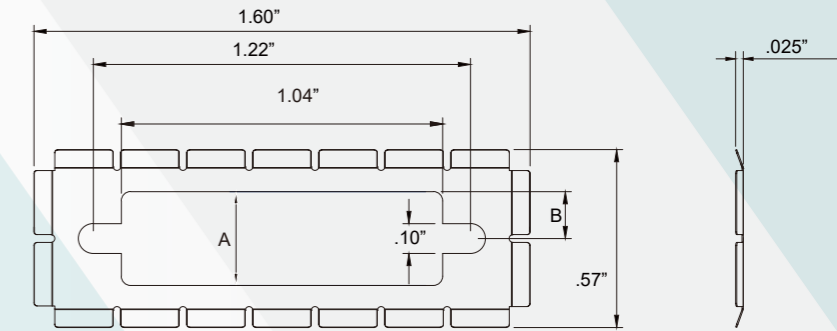

SC3E00082 Connector- .004" Thick

Part Number	Material	A	B
SC3E00082	Beryllium Copper	.26"	.13"

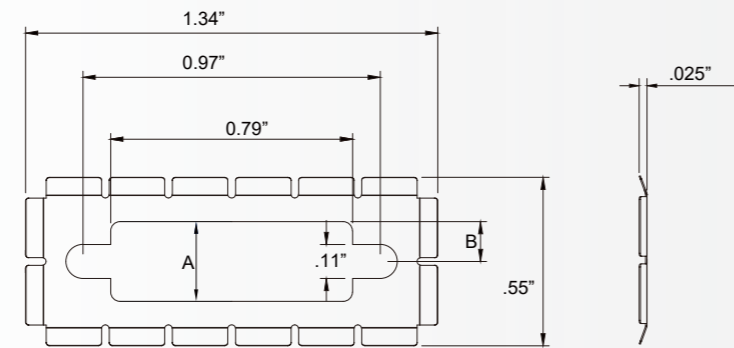

SC3E00080 Connector- .004" Thick

Part Number	Material	A	B
SC3E00080	Beryllium Copper	.26"	.13"

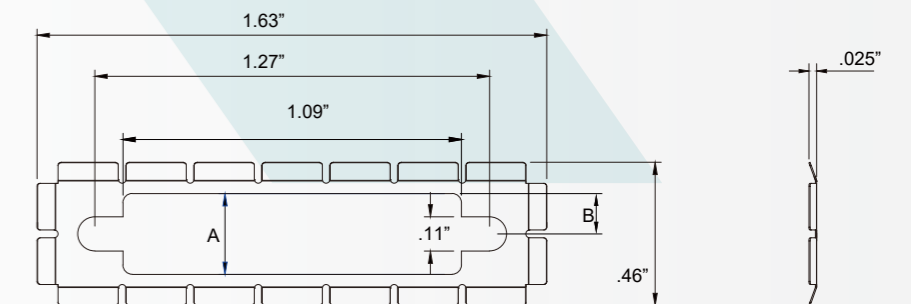

SC3E00075 Connector- .004" Thick

Part Number	Material	A	B
SC3E00075	Beryllium Copper	.26"	.13"

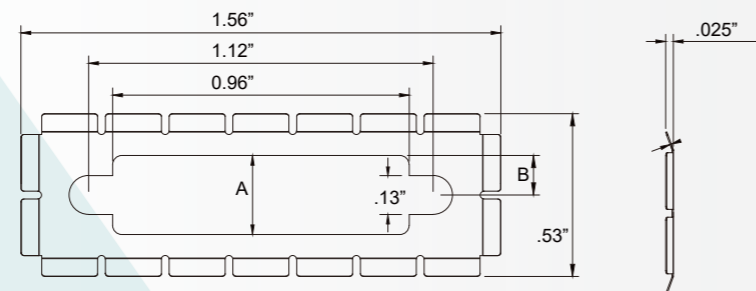

Application of Fingerstock Gaskets

EMI designers know and trust the consistent performance of Fingerstock (BeCu) gaskets. To date, BeCu yields the best electrical spring contact available in this industry. The BeCu mills have well established techniques and for decades have produced BeCu alloys per ASTM, SAE, JIS, and DIN specifications.

SEM uses only proven technology in creating BeCu springs, contacts and gaskets. Beginning with Alloy 25 (1/4 hard) BeCu, we stamp, form, and post heat-treat to a hardness of 340 to 390 DPH. This process is preferred in the EMI shielding industry because it has proven to produce the best electrical spring contacts. SEM BeCu EMI shielding gaskets are the most reliable in the industry.

SEM manufactures a wide variety of standard styles and sizes of BeCu gaskets. These gaskets operate in spaces from .010 inches up to .410 inches. Using BeCu materials as thin as .002 inch, we also offer many styles as soft gaskets that provide the low compression force needed in many applications. SEM also designs and manufactures custom spring contacts and gaskets.

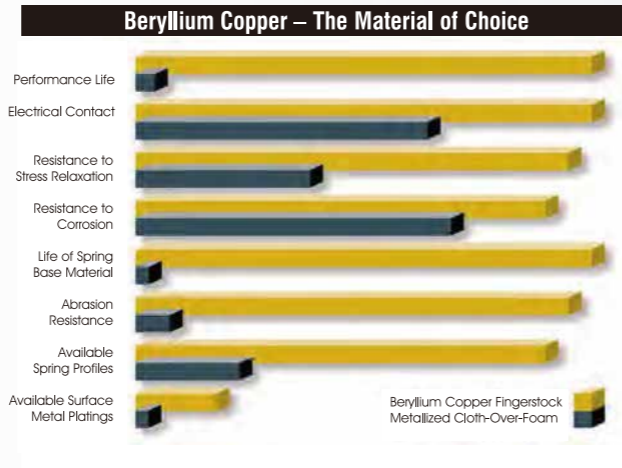

The operating temperature of heat-treated BeCu plays a significant role in its performance and properties. Using parts in an environment at or near the original heat treat temperature can have adverse effects. Therefore, designers should ensure that applications for BeCu gaskets or contacts are kept below 500°F (260°C).

FINGERSTOCK GASKETS DO TWO THINGS VERY WELL:

1. Their mechanical spring characteristics far surpass all other gaskets in the industry.
2. They offer the highest EMI shielding effectiveness.

SEM has been designing and manufacturing Fingerstock Gaskets since the early days of the computer and electronics industries. We combine these years of manufacturing and EMI experience with one key ingredient – the needs of the customer.

Our innovative Fingerstock Gasket designs are a direct result of our experience and customer input. Our Compact PCI line of EMI Gaskets is an example of a design that was driven by the needs of a customer and evolved into a line of gaskets that meet all the requirements for Compact PCI faceplate standards while providing superior mechanical and shielding performance.

SEM offers many standard off-the-shelf Fingerstock Gaskets as well as the engineering and custom manufacturing experience to help you solve your application. Whether you need one prototype or a large quantity order, our team at SEM is available to respond to your needs.

Ordering Information

When placing an order or requesting a quotation, please give part number, your required finish I.D. from the chart below, and required length.

PART NUMBER EXAMPLE:		
Stock Item	Finish Code	Length
TRHS1132	- T -	16

The above example is the "Slot Mount Series" gasket shown on page 7. The height is .11 inch and the width is .32 inch. The "-S-" indicates a soft gasket. The "T" indicates a bright tin finish. See list below for available finishes. This part is available in lengths of 16 inches. Consult factory for custom lengths or for availability in 25' coils.

Available Plating Finishes:		
Finish Type	Applicable Specifications	SEM Finish Code
Bright Finish	-	B
Bright Tin	ASTM B-545, CLASS A	T
Satin/Matte Tin	ASTM B-545, CLASS A	T*
Electro-less Nickel RoHS	ASTM B-733, SC 1, CLASS 1	N
Zinc/Chromate Clear	ASTM B-633, SC1, TYPE III	Z
Zinc/Chromate Yellow	ASTM B-633, SC1, TYPE II	Y
Clear Cadmium Chromate	ASTM B-766, CLASS 5, TYPE III	C
Yellow Cadmium Chromate	ASTM B-766, CLASS 5, TYPE II	C*
Bright Silver	ASTM B-700, TYPE 2, GRADE B, CLASS NA	
Satin/Matte Silver	ASTM B-700, TYPE 2, GRADE A, CLASS NA*	
Gold	ASTM B-488, TYPE I, CODE C, CLASS 1.2&3	

Standard plating finish is .0001 inch (.0025 mm) minimum. Plating processes and thicknesses may be varied to meet customer needs. Standard plating finish for gold is .00005 inches. See adjacent list of available finishes and consult factory for additional options.

Adhesive Mounting of EMI Gaskets

SEM tape mounted BeCu gaskets offer pressure-sensitive, double-sided adhesive for strong bonding to a wide variety of surface conditions. Ideal for all-purpose contact strips used in metal cabinets and electronic enclosures and is unaffected by temperatures from -67 to +250°F (-55 to 121°C).

Simply follow these four easy steps:

1. Remove all grease and oily residue with a solvent such as isopropyl alcohol/water mixture (rubbing alcohol) or heptane. Dry and smooth the mounting surface with emery cloth if necessary.
2. Peel off the protective paper backing from the 3M adhesive tape.
3. Place the gasket in correct position. Press firmly to ensure a good bond to surface. Avoid repositioning, which might impair the effectiveness of the adhesive or may bend or kink the strip. NOTE: On strips where fingers cover the solid portion of the gasket, pressure may be applied by inserting a mandrel in the strip and pressing down.
4. At room temperature approximately 50% of the ultimate strength will be achieved after 20 minutes, 90% after 24 hours, and 100% after 72 hours. In some cases bond strength can be increased and ultimate bond strength can be achieved more quickly by exposure of the bond to elevated temperature, e.g., 150°F (66°C) for 1 hour.

The SEM family of 3M taped shielding gaskets is solvent, moisture and temperature tolerant, and performs well in shear/wipe and compression applications of all kinds. The 3M adhesive meets a number of specs including Mil Standard. For further information please consult the factory.



Metals Galvanic Compatibility Chart

Group Number	Metallurgical Category	Compatible Surface Finishes	Compatible Surface Finishes							
			Gold	Silver	Nickel	Be-Cu	Tin	Sn-Pb	Zinc	
1	Gold, solid and plated, Wrought platinum, graphite carbon	.00	█	█	█	█				
2		.05	█	█	█	█				
3	Rhodium plating	.10	█	█	█	█				
4	Silver, high-silver alloys	.15	█	█	█	█	█			
5		.20	█	█	█	█	█	█		
6		.25	█	█	█	█	█	█	█	
7	Nickel, nickel-copper alloys, titanium, titanium alloys, Monel	.30	█	█	█	█	█	█	█	
8	Beryllium Copper, low brasses or bronzes, silver solder, copper, Ni-Cr alloys, austenitic corrosion resistant steels, most chrome-moly steels, specialty high-temp stainless steels	.35	█	█	█	█	█	█	█	█
9	Commercial yellow brasses and bronzes	.40	█	█	█	█	█	█	█	█
10	High brasses and bronzes, naval brass, Muntz metal	.45	█	█	█	█	█	█	█	█
11	18% Cr type corrosion resistant steels, common 300 series stainless steels	.50	█	█	█	█	█	█	█	█
12		.55	█	█	█	█	█	█	█	█
13	Chromium or tin plating; 12% Cr type corrosion resistant steels, most 400 series stainless steels, i.e., 410 and some cast stainless steels	.60	█	█	█	█	█	█	█	█
14	Terreplate, tin-lead solder	.65	█	█	█	█	█	█	█	█
15	Lead; high-lead alloys	.70	█	█	█	█	█	█	█	█
16	Wrought 2000 series aluminum alloys	.75	█	█	█	█	█	█	█	█
17		.80	█	█	█	█	█	█	█	█
18		.85	█	█	█	█	█	█	█	█
19	Wrought aluminum alloys except 2000 series cast Al-Si alloys, 5000 series aluminum	.90	█	█	█	█	█	█	█	█
20	Cast aluminum alloys other than Al-Si; cadmium plating	.95	█	█	█	█	█	█	█	█
21		1.00	█	█	█	█	█	█	█	█
22		1.05	█	█	█	█	█	█	█	█
23		1.10	█	█	█	█	█	█	█	█
24		1.15	█	█	█	█	█	█	█	█
25	Hot Dipped galvanized or electrogalvanized steel	1.20	█	█	█	█	█	█	█	█
26	Wrought zinc; zinc die cast alloys	1.25	█	█	█	█	█	█	█	█
27		1.30	█	█	█	█	█	█	█	█
28		1.35	█	█	█	█	█	█	█	█
29		1.40	█	█	█	█	█	█	█	█
30		1.45	█	█	█	█	█	█	█	█
31		1.50	█	█	█	█	█	█	█	█
32		1.55	█	█	█	█	█	█	█	█
33		1.60	█	█	█	█	█	█	█	█
34		1.65	█	█	█	█	█	█	█	█
35		1.70	█	█	█	█	█	█	█	█
36	Wrought and cast magnesium alloys	1.75	█	█	█	█	█	█	█	█
37		1.80	█	█	█	█	█	█	█	█
38	Beryllium	1.85	█	█	█	█	█	█	█	█

*Harsh Environment .10 volts Max. █ *Normal Environment .25 volts Max. █ *Office Environment .50 volts Max. █

Compression / Deflection Performance

SEM Part No.	Design Compressed Height	Compression Force (lbs./linear ft.)
TT000323	.018 (.46)	25
TT000634	.049 (1.24)	33
TT200650	.049 (1.24)	43
TUD00919	.072 (1.83)	30
TRH01132	.035 (.89)	34
TC041145	.090 (2.29)	19

SEM Part No.	Design Compressed Height	Compression Force (lbs./linear ft.)
TDT01445	.098 (2.49)	24
TAH02260	.140 (3.56)	25
TRH02260	.070 (1.78)	48
TFSC2376	.130 (3.30)	34
TC072599	.140 (3.56)	36
TFS02578	.150 (3.81)	36

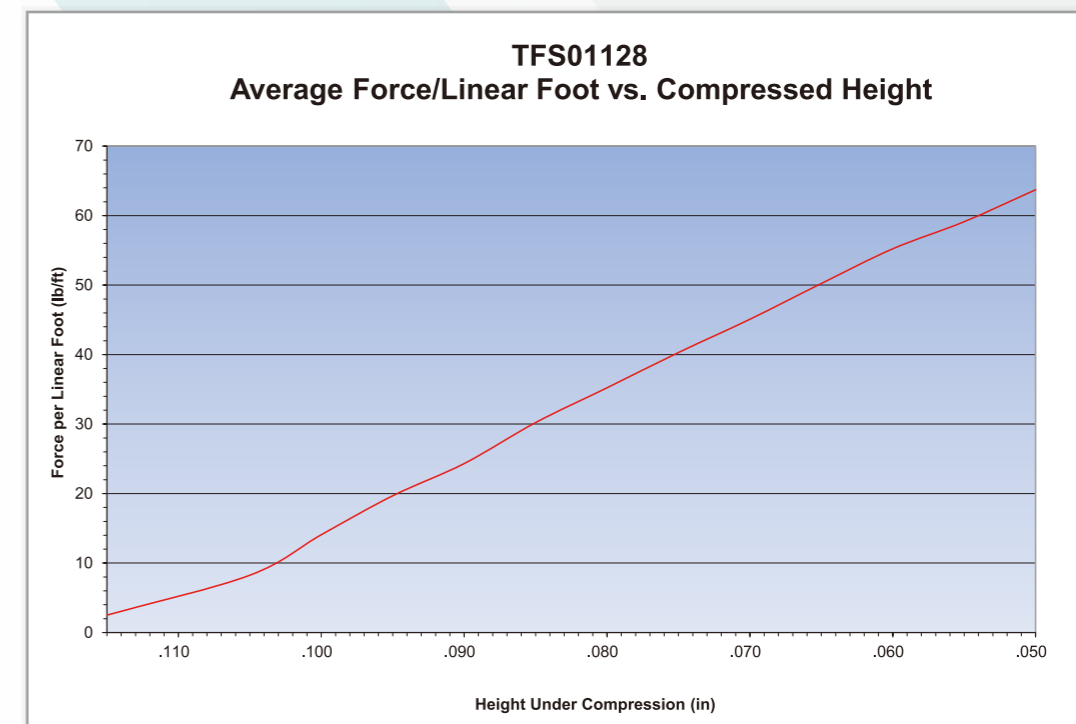

The data presented is based on testing and to our knowledge is accurate and true. Since applications, test methods, and test procedures may vary, we recommend that users of our products perform their own test to assure the suitability of these specific applications. We offer no product warranty, either expressed or implied, except that any product proven defective will be replaced. Freedom from present or future patent infringement cannot be guaranteed, nor can the suitability of our products for specific applications.

