

Profile E60

PSA Width: 0.250 [6.4]

inches [mm]

P-Shape

E60

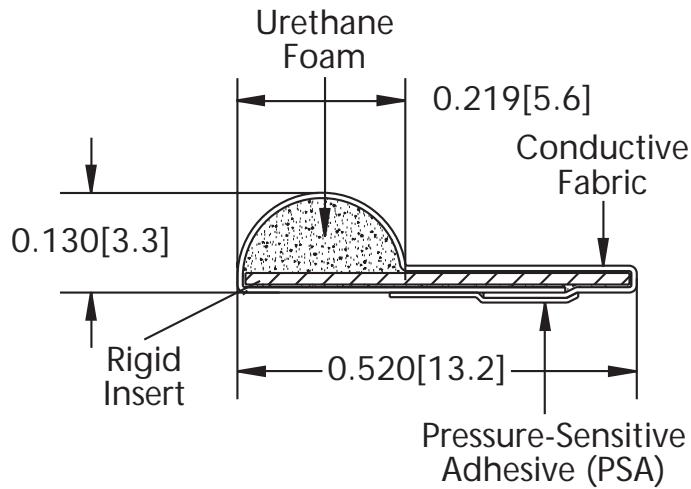

Dimensions for reference only

ACTUAL SIZE



Recommended Minimum Compression: 10% Recommended Maximum Compression: 70%

Contact resistance between a shielding gasket and the mating surface is related to applied load and percent compression of the gasket. This table is intended to assist in defining the optimum design range for an application. Determined by commonly accepted test procedures under controlled conditions, these values may differ from actual performance under specific operating conditions.

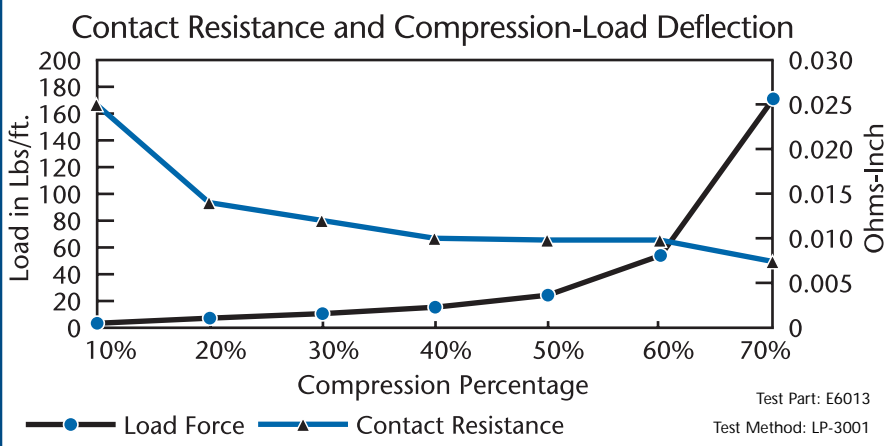

UL is a registered trademark of Underwriters Laboratories, Inc.

See tab 2 (Gaskets Overview) for icon definitions

The preceding information is believed accurate by SEM. In no event, however, shall SEM have any liability whatsoever for inaccuracies or omissions contained therein. In all cases, details and values should be verified by the customer. These products are covered by various U.S. and foreign patents.

SCHLEGEL
electronic materials

www.schlegelemi.com